

ARCAM

D100 CASSETTE DECK SERVICE MANUAL

CONTENTS

Block Diagram	2
Circuit Description	3
Playback amplifier circuit	3
Record amplifier circuit	3
Mother PCB Power Supply	3
Dolby Boards	4
Callbration Board	4
Display Board	5
Control Board	5
ADJUSTING AND CHECKING THE MECHANISM	9
Exchanging pinch roller	9
Checking pinch roller pressure	9
Exchanging recording/playback head	9
Recording/playback head installation	10
Recording/playback head adjustment	10
Adjustment of tilt angle	10
Azimuth adjustment	11
Height adjustment (with TEAC-94201)	11
Erase Head Exchange	11
Tape guide height check	11
Checking recording/playback torque	11
Back tension torque check for recording/playback	12
Checking Reel Drive Thrust Movement	12
FF and REW Torque Check	12
FF and REW Time Check	12
Accidental erasure prevention, tape type switch function check	12
Pulse detecting LED and reel table clearance check	12
ADJUSTING THE ELECTRICAL SECTIONS	13
Equipment necessary for adjustment	13
Tape path check	14
Azimuth adjustment	14
Tape Speed Check and Adjustment	15
Playback System Adjustment	15
Checking playback frequency characteristics	15
Recording System Adjustment	15
Recording Bias Level Adjustment	15
Exploded View of Mechanism	17
Frequency Response Limits	18
Adjustment & Setup Procedure	19
Dolby encode characteristics for B/C/S NR	21
Change of Mains Voltage	22
Test Points on Mother PCB	23
Test Points on Mother PCB	24
D100 Circuit Diagrams	25

Block Diagram

D100 CASSETTE DECK BLOCK DIAGRAM (LHC ONLY)

PLAYBACK SYSTEM
 A. BEX TCC-130 DOLBY LEVEL
 400Hz 200nVb/M

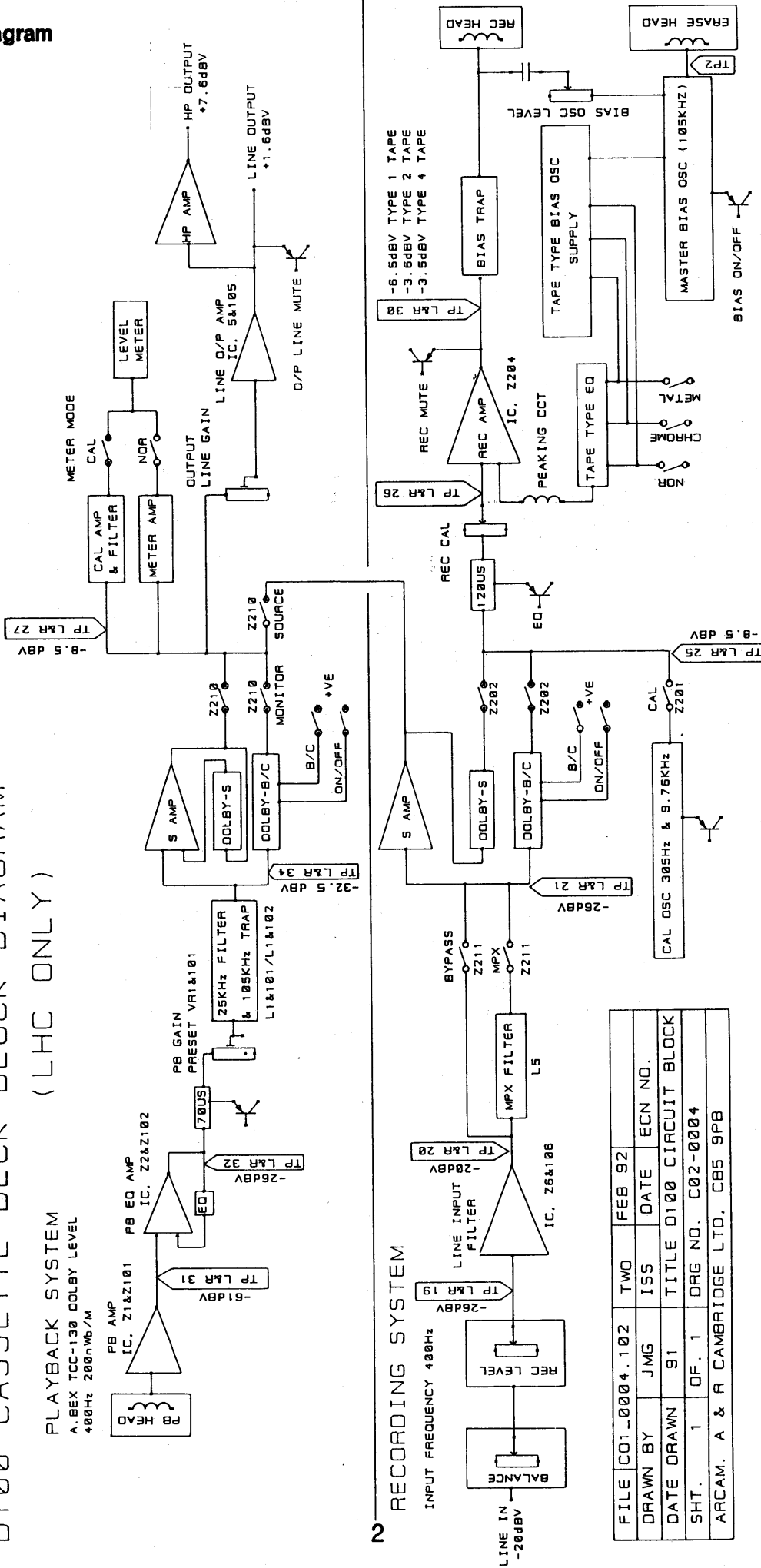

FILE	CO1_0004.102	TWO	FEB 92
DRAWN BY	JMG	ISS	DATE
DATE DRAWN	91	TITLE	D100 CIRCUIT BLOCK
SHT.	1	OF. 1	DRG NO. C02-0004
ARCAM. A & R CAMBRIDGE LTD. CB5 9PB			

Circuit Description

Playback amplifier circuit

Z1 forms the first gain stage with R1, 2 setting the gain of the stage. Z2 is the second stage and has reactive feedback provided by R5, 6 and C1 to give the 120us de-emphasis. 70us de-emphasis is done by switching in Q1 to introduce R7, 8 and C2 into the feedback loop. This switching is controlled from the microprocessor.

The signal passes through presets RV1, 101 which set the Dolby playback level. These are factory set. L1, 101 and L2, 102 form a 105kHz bias trap and a 25kHz low pass filter to filter out ultrasonic noise which would cause the Dolby circuits to mistrack.

Q2 is used to mute the audio signal and is controlled by the microprocessor. The audio signal is bussed to the playback Dolby cards B, C and S.

The microprocessor then selects the required output from these cards with the electronic switches in Z210. Note the control voltages for these switches are positive and negative. Electronic switches Z201, 202 are also used to provide either playback or source monitoring. The signal passes via the output level control, P203, to the output amplifier Z5 which amplifies the signal gain set by R45 & R46 before passing onto the line out phono sockets and mute relay. The relay is not in series with the signal but shorts the signal to ground when muting. The input to the headphone amplifier Z203 is derived from the same point.

Record amplifier circuit

The line in signal passes through the balance and master record level controls onto an active low pass filter formed by Z6 and its associated circuitry. This removes information above 30kHz at 12dB/octave. Following this is the MPX filter which can be switched in via Z211 to remove the 19kHz pilot tone when recording from FM tuners.

The audio signal is then bussed to the Dolby record cards for processing. The 'source' signal is taken from the Dolby S amplifier prior to Dolby type selection switching. The required encoded signal is selected via Z201, 202 by the microprocessor. The output from the Dolby cards can be disabled to enable calibration signals to be used for calibrating for different tape types. The chosen signal passes through a 70us de-emphasis network Q7, R41, C45 which is microprocessor controlled and onto the record calibration control P204. Record mute (pause) is controlled by Q3 from the microprocessor.

The signal passes to the factory preset record levels VR2, 102 and then onto the record amplifier Z204. The feedback around this IC contains reactive components to provide peaking and equalization for the 3 tape types and the required components are switched in by Q4, 5, 6 automatically by the microprocessor from the positions of the 'fingers' within the tape mechanism. The signal then goes through a 105kHz trap, L3, C32, to prevent the 105kHz oscillator being loaded by record amplifier.

The signal is now blended with the record oscillator signals whose amplitude is controlled by the microprocessor and is dependant on tape type and the manual bias setting.

The erase oscillator is formed by L202, Q203, 204 and its amplitude is varied by the supply voltage from the adjustable regulator Z212.

The different feedback networks switched in by Q205, 206 and 208 provide the required output voltage. There are factory preset bias level adjustments within these circuits also.

The oscillator is switched off by taking the adjust pin of the regulator as low as possible and effectively removing the supply from the oscillator block.

Mother PCB Power Supply

AC from the transformer is rectified and smoothed by D201-204, C213, 214 and then regulated by

complementary regulators to provide +/- 6V and +/- 15V. The unregulated supply is used to power the bias oscillator regulator and mute circuit IC Z205. This mute circuit also has an AC supply which is half wave rectified to supply a reference voltage to the mute IC.

To prevent switching noises on the outputs the mute circuit is enabled for a short time, when a front panel button is pressed, by the microprocessor via Q209. There is also a 2 second switch on delay again controlled by the microprocessor. In calibration mode the output is muted via D209 to prevent damage to speakers.

Dolby Boards

Dolby B/C

The Dolby B/C functions are provided by the Sony CXA1332 two channel encode/decode Dolby noise reduction processor.

The playback and record boards are identical but are factory preset by the status of pin 5, via J201, to provide the required function. (Playback link J201 fitted - Record no link.)

Pin 26 of the IC is the control pin to provide B, C or no noise reduction. This is controlled by the microprocessor. With no noise reduction selected the Dolby boards provide a flat frequency response gain stage. The control line status is 0v/High/Low for B/C/Off respectively.

Dolby S

This is provided by the Sony CXA1417 Dolby S noise reduction system. This chip provides all encode and, with the addition of IC1, decode functions.

The Dolby S boards are single channel so 4 are required for stereo encode/decode.

The distinguishing feature between record/playback is the way in which the Dolby S chip is incorporated into the signal path of IC1. Links J2, J2 provide this function (J1 fitted for playback J2 for record).

The Dolby level can be adjusted to 388mV by VR1 on each pcb to match the level on the Dolby B/C boards which should be calibrated first.

All Dolby boards have a +/- 6V supply from the mother board and the Dolby level of 388mV is given when used with Dolby tape A.BEX 400Hz 200nWb/M.

Calibration Board

The calibration board consists of two separate sections.

1) One section is a switchable meter driver and filter stage.

In normal mode the audio signal is also routed through the calibration board via emitter followers Q2, Q3 and CMOS switch Z1 to the display pcb.

In calibration mode the right hand channel only is sampled and filtered to drive the left and right meters individually to give bias on the right hand meter and calibration on the left. Q5 and Q6 are switched in to provide a DC current to the display to increase the display resolution to 1/2dB per segment from a logarithmic scale.

2) The second section of the board generates the calibration tones.

The master crystal oscillator XTAL 2.5MHz is divided down by Z6 (4060) to provide 2 frequencies of 305Hz for calibration and 9.76 kHz for bias. These 2 square wave signals are individually filtered by Z4 (LF), Z5 (HF) and their associated components loop to remove all harmonics to provide suitable sinewave outputs.

These two frequencies are mixed which gives a -20dB Br Dolby level of 39mV of the fundamental frequencies. The calibration circuit is switched by the microprocessor when required and picked up after the playback Dolby boards in the 'off' mode and feedback to the calibration board via connector 'P'.

The levels are factory set by VR4 for calibration and VR2 for bias.

Display Board

IC3 (BA6822) is the LED driver IC driven by the current from Q2, 3 on the calibration board. In calibration mode the peak hold function is disabled. A 'dither' circuit based around Q5, C7 is used to make the display LED's appear to change smoothly from one LED to another instead of abruptly coming on and so increasing the resolution.

The remote control receiver IC4 picks up signals from the remote control handset and sends the appropriate signals to the microprocessor.

The fluorescent display is used as a real time counter and driven by the microprocessor. IC1 and IC2 are used to drive appropriate LEDs to indicate 'Pause', 'Play', 'Fast Forward' etc., from signals from the microprocessor and PIC. These are required because the microprocessor was originally designed for use with a fluorescent display with legends on it for 'Pause', etc.

Control Board

1. General Circuit Description

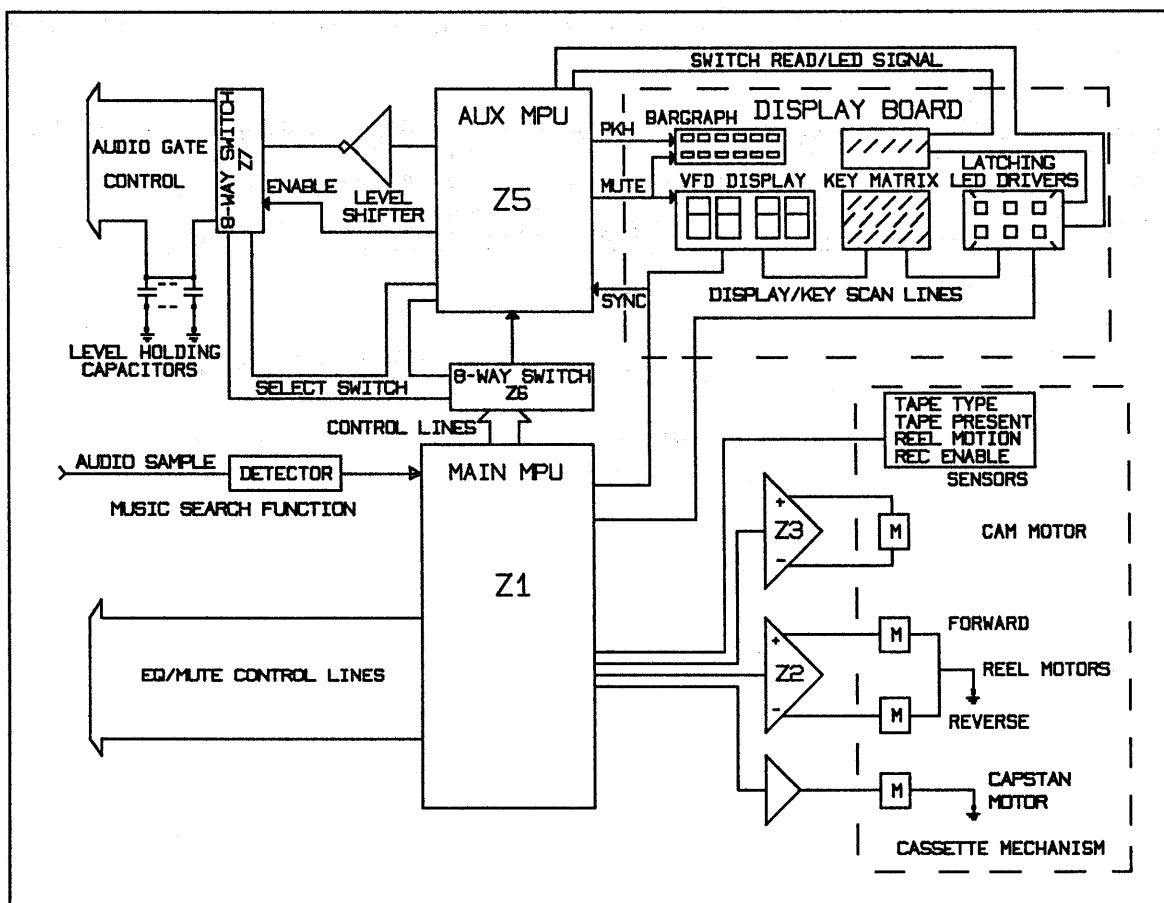

Control Board Block Diagram

The control board receives requests from the front panel push buttons and sends control signals to the audio board and power to the cassette mechanism to carry out the required functions. Signals are also sent to the display VFD and LEDs to show the machine status.

At the heart of the control board is a **Microcontroller**, Z1, this was designed for use in a cassette deck

with Dolby B/C, a large VFD display (no LEDs) and the same cassette mechanism as is used in the D100. Used in its intended environment, Z1 needs few external components. These are mainly power supplies and the motor driver chips, Z2 and Z3, but due to the use of LEDs to indicate some functions, the addition of Dolby S and a very high performance audio section, a second microcontroller is required in the D100. Enter Z5, a small auxiliary microcontroller for this very purpose.

Both Z1 and Z5 are effectively small computers running a small program stored in an internal Read-Only-Memory. The program controlling Z1 is pre-defined. The program controlling Z5 was written here by ARCAM and is burned into the chip before it is inserted into the PCB.

The **auxiliary microcontroller, Z5**, is used to handle the Dolby selection and features special to the D100 such as Calibration mode. It has few IO pins compared to Z1 so several 'tricks of the trade' has been used to expand its functionality.

Two **8-way switches, Z6 and Z7**, have been used to expand the number of inputs and outputs available to Z5. Z5 simply dials up which switch to read or write to using three control lines. Also, some of the pins used to signal LEDs are used also as inputs by going high impedance for a few microseconds whereupon the pin state is set through a resistor. After the state is read the pin reverts back to an output and re-asserts its previous state. R43 R44, R45 and R54 supply information to Z5 in this way concerning switch states and synchronization with Z1 (Z1 and Z5 have independent clocks).

The **control signals** required by the audio board of the -5v/+5v type are generated from a common level shifter, Q9 and Q10. The output of the level shifter is routed though to the appropriate control line via the 8-way switch Z7. These lines can not be loaded as only the capacitors C26 to C33 hold the output level when the switch is not selecting a particular control line. Since all these lines except B/C SELECT are driving high impedance CMOS inputs, this doesn't matter. B/C SELECT is connected to the level shifter for much longer than any of the other control lines and has a large capacitance, C26 to hold its state. Otherwise it is pulled to 0V by a 30K resistors on the Dolby B/C chips.

When using a **'scope** to test any of the signals on the pins of Z5 you will find the waveform has severe **jitter** and it will be difficult to see any steady waveform. The reason for this is that if any digital signals cause interference, random noise does not contain any 'tones' which could break through the audible noise floor on the audio board (not that this happens anyway!). Noise energy is spread across the frequency spectrum rather than being concentrated at any one or more frequencies. To remove this random jitter for test purposes, apply +5v to the test pad 'TESTMPU' and Z5 will run without jitter until the power is switched off.

2. Music Search

The main MPU, Z1, is programmed to offer a music search facility. When selected, the cassette mechanism goes into fast forward or rewind with the tape head positioned very close to the tape so that audio signal (music) can be detected. If the signal stops for a short time, then the MPU assumes that this is the space between two music tracks on the tape and selects 'PLAY'.

Board Connections

The most used types of signal drivers are classed by letter code as shown below.

- A** +5v active high, 0v active low
- B** +5v active high, -5v active low
- C** +5v active high, -22v passive low

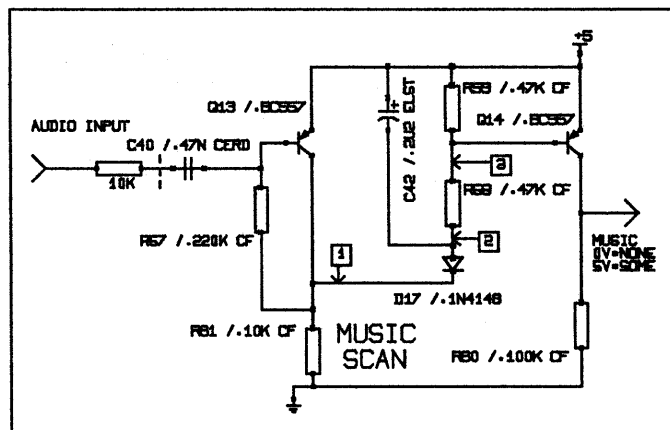

Music Search Circuit

note: Type B outputs must not be loaded, measurement may be made by 'scope or DMM but not by a moving coil meter.

Sockets listed in alphabetical order

K

<u>Pin</u>	<u>Name</u>	<u>Function/signal type</u>	
1	Normal	A, Output	high = Tape is Normal type I
2	Chrome	A, Output	high = Tape is Chrome type II
3	Metal	A, Output	high = Tape is Metal type IV
note: Only one of pins 1,2, and 3 can be high at any one time.			
4	120/70us	A, Output	high = Select 70us tape EQ
note: Pin 4 is 5v if pin 2 or 3 is high i.e. for Chrome or Metal			
5	Play mute	A, Output	high = Playback amp muted
6	Rec mute	A, Output	high = Record amp muted
7	Cal	B, Output	high = Select Calibration mode
8	Bias	A, Output	high = Bias oscillator on
9	Gnd		
10	Music	Input	Audio from playback amp. Used to detect tape signal during music search.
11	+5Van	Power in	Analogue +5V supply input
12	-5Van	Power in	Analogue -5V supply input
13	GNDan	Power in	Ground for +5Van and -5Van
14	0v	Power out	Digital ground reference

L

note: All signals are outputs

<u>Pin</u>	<u>Name</u>	<u>Function/signal type</u>
1	S Record Gate	B, Select Dolby S Record board
2	Source Gate	B, Select Source Monitor
3	S Play Gate	B, Select Dolby S Playback board

M

note: All signals are outputs

<u>Pin</u>	<u>Name</u>	<u>Function/signal type</u>
1	B/C Select	-5v = Select NO DOLBY on Dolby B/C board 0v = Select Dolby B on Dolby B/C board +5v = Select Dolby C on Dolby B/C board
2	BC Record Gate	B, Select Dolby B/C Record board
3	BC Play Gate	B, Select Dolby B/C Playback board
4	MPX Fil off	B, Inverse of MPX Fil
5	n/c	
6	MPX Fil	B, Select MPX filter active

S

note: All A.C. power inputs from PSU transformer

<u>Pin</u>	<u>Function</u>
1	8v rms phase #1 for motor/logic
2	Centre tap,0v for 8v rms and 18v rms supplies
3	8v rms phase #2 for motor/logic
4	18v rms for VFD display drive
5	0.7v rms phase #1 for VFD display heater
6	Centre tap,0v for 0.7v rms VFD display heater
7	0.7v rms phase #2 for VFD display heater

T

<u>Pin</u>	<u>Name</u>	<u>Function/signal type</u>
1	n/c	
2	S0A	C, Key matrix select line 0, VFD display segment A
3	S1B	C, Matrix line 1, VFD segment B
4	S2C	etc.

D100 SERVICE MANUAL

...		
10	S8I	
11	1G	C, Select VFD display grid 1
...		
17	7G	C, Select VFD display grid 7
18	K3	A, Read key switch matrix return line 3
...		
21	K0	A, Read key switch matrix return line 0
22	-22v	-22v supply output
23	0v	0v output
24	+5v	+5v supply output
25	Fil	VFD display heater supply #1
26	Fil	VFD display heater supply #2

U

<u>Pin</u>	<u>Name</u>	<u>Function/signal type</u>
1	n/c	
2	n/c	
3	Disp	A, Output Display and VU meter mute
4	Remote	A, Input Remote control received data
5	Calsw	Input, Pulls +5v, CAL switch pressed
6	Dispsw	Input, Pulls +5v, DISP switch pressed
7	Dolby S	A, Output Dolby S lamp
8	Dolby C	A, Output Dolby C lamp
9	Dolby B	A, Output Dolby B lamp
10	Mute	Input, Pulls +5v, Mute switch pressed
11	Cal	A, Output CAL mode lamp, VU PKH disable
12	Playsp	A, Output Cassette playing/recording
13	Reelf	A, Output Cassette drive forward motion
14	Reelr	A, Output Cassette drive reversing

V

<u>Pin</u>	<u>Name</u>	<u>Function/signal type</u>
1	Cam F	Output, Cam motor #1
2	Cam R	Output, Cam motor #2
3	Encoder	C, Output, Select encoder
4	Key3	Input, Select switch encoder #3
5	Key2	...
6	Key1	
7	Key0	Input, Select switch encoder #0
8	Switch	C, Output, Select switch sensors

W

<u>Pin</u>	<u>Name</u>	<u>Function/signal type</u>
1	Gnd	Output, Ground 0v
2	Capstan	Output, Capstan motor
3	Reel F	Output, Forward reel motor
4	Reel R	Output, Rewind reel motor
5	Pulse R	Input, Feed spool motion sensor
6	+5v	Output, +5v supply
7	Pulse F	Input, Takeup spool motion sensor

ADJUSTING AND CHECKING THE MECHANISM

Refer to exploded drawing of mechanism,(page 17), on numerical references.

1. Exchanging pinch roller

Before exchanging the pinch roller, clean the tape contact surfaces of the pinch roller and of the capstan shaft.

Defects in tape playing are primarily caused by a dirty pinch roller or capstan shaft.

The right pinch roller arm (23) can be detached by removing the spring (24) and the slit washer (317).

The left pinch roller arm (104) can be taken out by removing (106), the nylon nut (315) and washers (107) and (108).

After changing the pinch roller, run a A.BEX TCC-902 mirror cassette 12um and check that no tape curling occurs at the tape guide and the tape guide part on the record/playback head.

2. Checking pinch roller pressure

In the playback condition, hook a stick type spring balance to the bracket on the central axis of the pinch roller. After pulling the pinch roller away from the capstan shaft, let the pinch roller contact the capstan shaft as it is and check that the readings on the spring balance are 350 to 450 g on the right side and 150 to 250 g on the left when the pinch roller starts turning. If the readings exceed the standard values, replace spring (24) or (106).

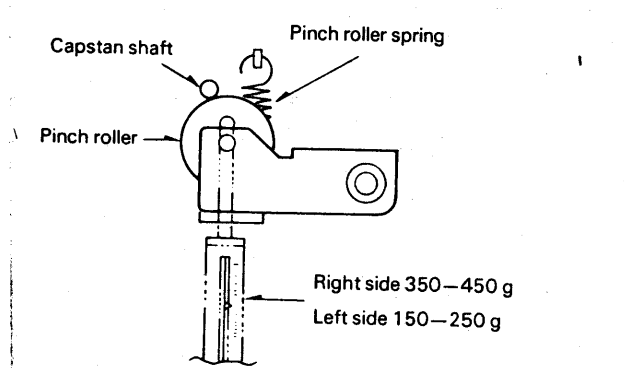

3. Exchanging recording/playback head

Remove the front panel first.

3-1 Dismounting recording/playback head

(1) Detach the recording/playback head by removing the TWO locking screws (311) and the azimuth adjusting nut (10).

(2) Unsolder the head wire and separate the mechanical unit to dismount the recording/playback head.

3-2 Recording/playback head installation

Assembly is the reverse of the installation procedure described in section 3-1. The soldering for the head wire is performed as shown in Figure 3-1.

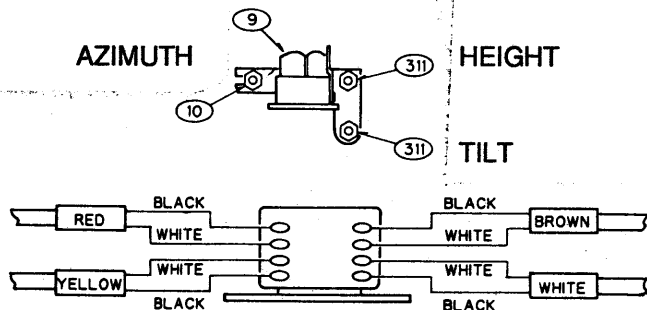

4. Recording/playback head adjustment

4-1 Height adjustment (adjust with head adjustment jig THG-801)

- (1) Set THG-801 (jig board) on the mechanical unit and perform the adjustment by turning the special height adjustment nut (10) so the 3.8mm part on THG-801 (jig shaft) can move without touching the tape guide on the recording/playback head (9).
- (2) Turn the azimuth adjusting nut (10) so that the recording/playback head does not tilt while adjusting the height, and make a rough visual adjustment.

4-2 Adjustment of tilt angle

- (1) Set THG-801 (jig board) in the mechanical unit and place THG-801 (jig shaft) on the recording head to inspect the gap between the jig board. If the jig shaft is tilted forward, the tilt screw (311) is too tight. Loosen it slightly and adjust the tilt screw (311) until the jig stick is parallel to the jig board and the gap is completely eliminated.
- (2) Readjusting the tilt may cause the height adjustment nut to slip. After adjusting the tilt, be sure to check the height. If the height is misaligned, turn the special height adjustment nut (311) and the tilt screw (311) to the same angle to shift the recording/playback head so it is parallel to the jig board for height re-adjustment. After the adjustment is completed, tighten the lock nuts.

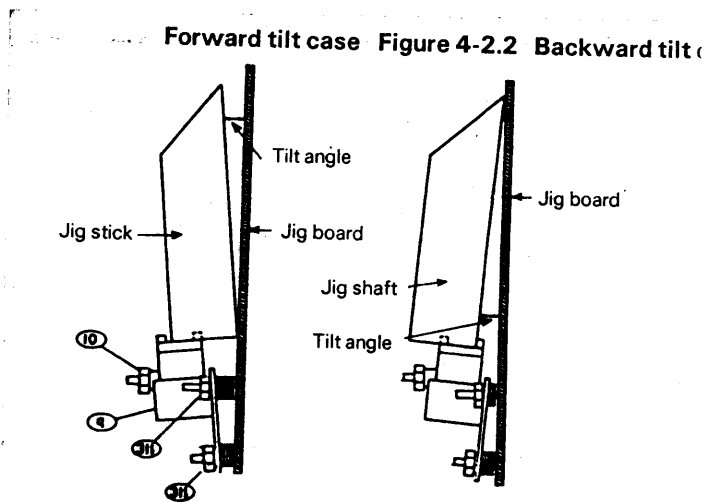

4-3 Azimuth adjustment

Playback test tape A-BEX TCC-153 and perform the adjustment by turning the azimuth adjustment nut (10) until A and B in the Lissajous wave figure are at the maximum output signal and minimum phase positions respectively.

The Lissajous wave is created on the oscilloscope by connecting the LHC to the CH1 and the RHC to CH2, with the oscilloscope in the X-Y Mode and CH1 "IN" phase with CH2.

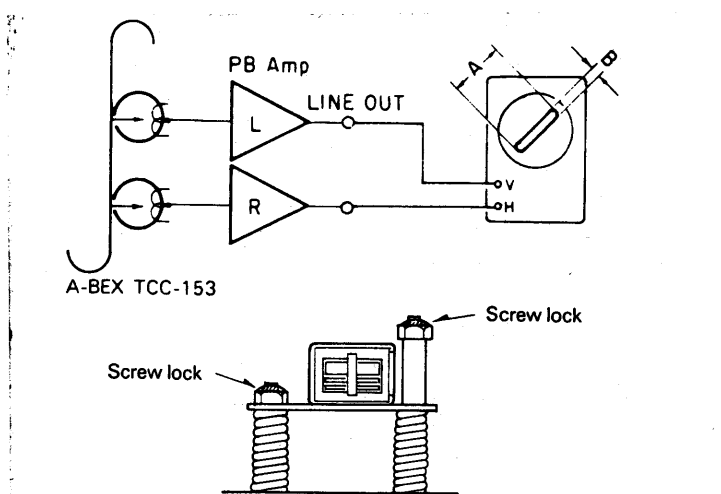

After azimuth adjustment is completed, check again to make sure there is no change in the head height. (Use the TEAC-94201 Test tape).

4-4 Height adjustment (with TEAC-94201)

Playback the TEAC-94201 Dolby-S head height test tape. Perform the adjustment by turning the head height adjustment nut (311) so LEFT and RIGHT channels are of equal level at both test frequencies (note 1dB = difference between channels is equal to approximately 15 microns) Dolby limit is 4dB difference for Dolby-S.

After the adjustment is completed, secure the lock nuts on the adjusted parts.

5. Erase Head Exchange

5-1 Remove the front panel first.

5-2 Remove the locking screw (171) for the erasure head.

5-3 Remove the solder on the head wire, and separate the mechanical unit to dismount the erasure head.

6. Tape guide height check

Set the jig board THG-801 on the mechanical unit. Adjust it by turning the check adjustment nut (315) so that the 3.8mm part on the jig can move without contacting the tape guide part of the tape guide (103).

7. Checking recording/playback torque - Sony TW-2111A

Load a cassette-type torque meter and check that the reading on the torque meter at the median value is 30-80 g-cm during playback.

If the reading is outside the standard, check the voltage of the reel motor (3.3V \pm 0.3V). If the voltage is low the torque is weak and when the voltage is high the torque is strong.

Also check the reel thrusting mechanism in Item 8.

8. Back tension torque check for recording/playback - Sony TW-2121A

Load a cassette-type torque meter to check that the reading the torque meter for recording/playback is 6-15 g-cm and there is no unevenness.

If the reading is outside the standard values, check the reel thrust mechanism or replace the spring (7).

9. Checking Reel Drive Thrust Movement

Check that the thrust movement is 3.0 to 4.0mm.

10. FF and REW Torque Check - Sony TW-2231

When using cassette-type torque meter:

Check that the readings of 80-160 g-cm is given in fast-forward and rewind

11. FF and REW Time Check

Load a C60 cassette tape and check that the FF and REW time is 80 to 110 seconds. If the reading is outside the standard values, check Items 8 and 10.

12. Accidental erasure prevention, tape type switch function check

Check that switch (83) is functioning normally depending on whether a hole is present or not on the cassette tape.

13. Pulse detecting LED and reel table clearance check

Check that the gap between the surface of the shutter part of the reel table and LED is approximately 1mm.

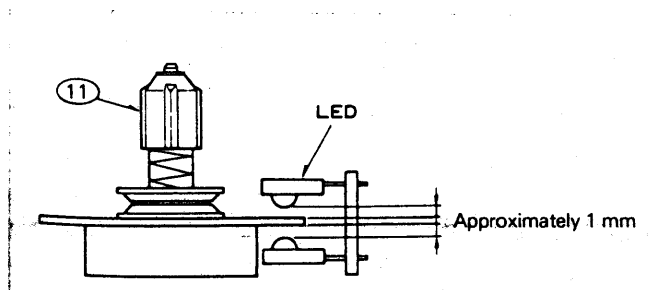

ADJUSTING THE ELECTRICAL SECTIONS

Equipment necessary for adjustment

- (1) Low frequency oscillator (20Hz to 20KHz)
- (2) Variable resistance attenuator
- (3) Electronic voltmeter
- (4) Oscilloscope (2 Channel)
- (5) Frequency counter
- (6) 4mm nut driver
- (7) A-BEX TCC-902 (Mirror cassette)
- (8) A.BEX THG-801 (Mechanical Head Height jig)

Necessary Test Tapes for adjustment

- (1) A.BEX TCC-153 (Azimuth)
- (2) A.BEX TCC-130 (Dolby level 200nWb/m)
- (3) A.BEX TCC-110 (Tape speed, wow & flutter)
- (4) A.BEX TCC-161B (120uS Playback response)
- (5) A.BEX TCC-261B (70uS Playback response)
- (6) TEAC MTT-94201 (Head Height tape)

Necessary Recording reference Tapes for adjustment

- (1) TDK AC-224 Alignment tape (AD Equivalent)
- (2) TDK AC-513 Alignment tape (SA Equivalent)
- (3) TDK AC-712 Alignment tape (MA Equivalent)

Torque Gauges necessary

- (1) SONY TW 2111A (Forward tension torque)
- (2) SONY TW 2121A (Back tension torque)
- (3) SONY TW 2231 (FF & REW Torque)

Adjustment Notes

- (1) Clean the head surface, capstan axis, pinch roller, etc. with gauze or cotton swabs soaked with alcohol before adjusting.
- (2) Demagnetize the recording head and erasure head with the head eraser.
- (3) Completely demagnetize the adjusting driver.
- (4) Set function switches as follows unless specifically indicated.

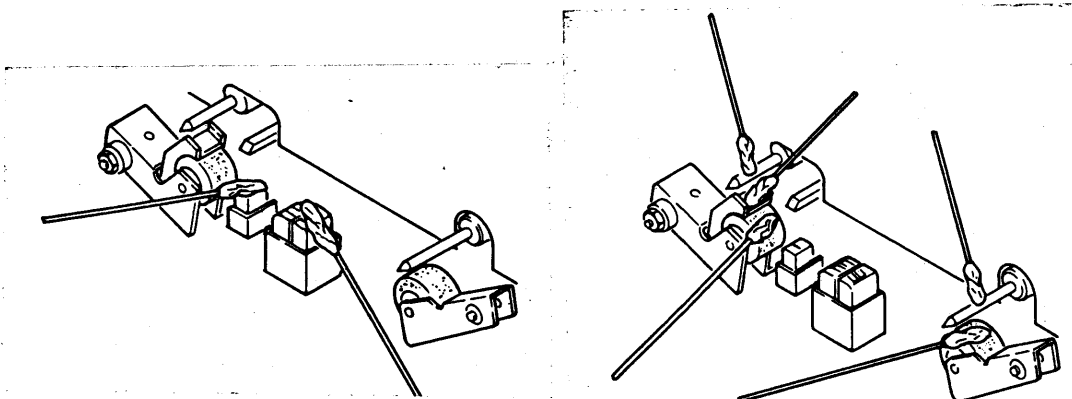

MONITOR switch: TAPE
 RECORD level: Maximum (fully clockwise)
 DOLBY NR switch: OFF
 BIAS volume: Centre (clicking detent in centre)
 OUTPUT volume: Maximum (fully clockwise)
 BALANCE volume: Centre (clicking detent in centre)

1. Tape path check A.BEX TCC-902 Mirror cassette

Load a mirror cassette for playing and examine the area around the fixed guide of the recording/playback head in playback with lighting and check that the tape edge is not contacting the tape guides. The tape path is the most important element that determines the quality of the entire cassette deck. Make every effort to avoid moving the adjusting parts. Also, refer to "Adjustment and check of mechanical system" for exchanging and adjusting the recording/playback head.

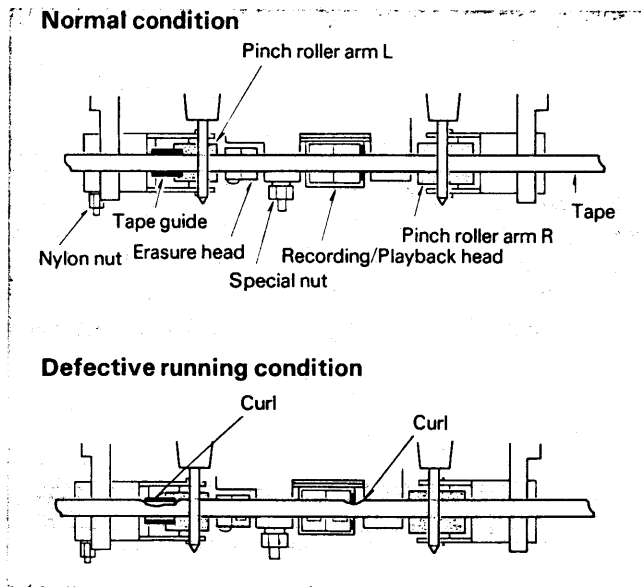

2. Azimuth adjustment

2-1 Playback test tape A-BEX TCC-153 and perform the adjustment by turning the azimuth adjustment nut (10) until A and B in the Lissajous wave figure are at the maximum output signal and minimum phase positions respectively. After azimuth adjustment is completed, check again to make sure there is no change in the head height. (See page 11 Sec.4.4).

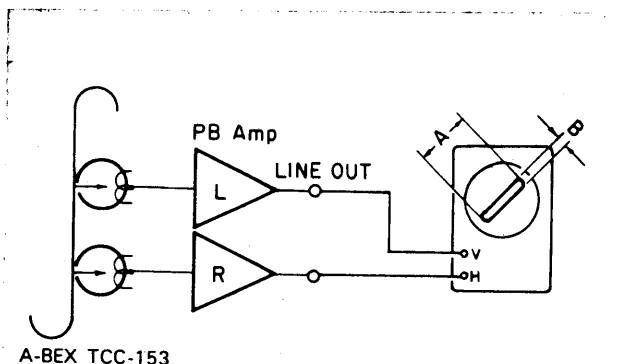

3. Tape Speed Check and Adjustment

3-1 Connect the frequency counter to the LINE OUT terminal and load A-BEX TCC-110 test tape.

3-2 Playback the test tape. When the test tape playback stabilizes at the centre part of the tape, adjust the regulator on the back side of the capstan motor so that the frequency counter reading is set within the range of 3000Hz +/- 6Hz.

4. Playback System Adjustment

4-1 Dolby Playback level

Playback Dolby level (A-BEX TCC-130) test tape and adjust (Lch) VR1 and (Rch) VR101 so that the level of 388mV (0dBr) is given on DECODE Dolby B/C card test points TP1 (Lch) & TP2 (Rch).

After the Dolby B/C level is set adjust the DECODE Dolby-S level to 388mV (0dBr) using test point and preset on the TWO Dolby-S PCB.

4-2 Checking playback frequency characteristics

Playback the test tapes (A-BEX TCC-261B and 161B) and check that the frequency characteristics conform to the specified standard. (see playback limits) Page 18.

Note: Before checking the playback frequency response, first adjust the azimuth using the 8 kHz signal at the beginning each of the A.BEX test tape. Also, after checking the playback frequency, make sure to readjust the azimuth with the test tape (A-BEX TCC-153) and then lock the adjustment screw.

5. Recording System Adjustment

5-1 Adjusting record bias oscillator Frequency Adjustment.

(1) With the deck in record adjust L202 to give a frequency of 105KHz on TP2. (use 10X probe)

5-2 Adjusting record amp to Dolby Level.

(1) Adjust the line input level to give 388mV (0dBr) / 400Hz on ENCODE Dolby B/C test points, TP1 & TP2. The line input level will be about 80 to 100mV.

After the Dolby B/C level is set adjust the ENCODE Dolby-S level to 388mV (0dBr) using test point and preset on the TWO Dolby-S PCB.

(2) Load a test tape TDK AC-224 (AD Equivalent) and make a recording using 0dBr / 400Hz input signal and adjust VR2 (left channel) and VR102 (right channel) to give a 388mV on playback Dolby B/C test points TP1 & TP2.

5-3 Recording Bias Level Adjustment

Monitoring the Line output, reduce the input signal by -25dBr from the above Dolby level.

(1) Using a reference tape as recommended (TDK AC-224) set the bias by recording a 10kHz signal and adjusting VR3 (LHC) and VR103 (RHC) to give a flat response reference to 400Hz.

Note: VR3 & VR103 are master bias current presets and are common to all three tape types, so they must be set **first**.

If VR3 or VR103 are reset after the "Chrome" & "Metal" tape types have been calibrated then "Chrome" & "Metal" will have to be re-calibrated.(See 2 & 3 below).

(2) Using TDK AC-513 (SA Equivalent) test tape set the bias by recording a 10KHz signal and adjusting "CHROME" preset VR202 for both LHC & RHC to give a flat response.

D100 SERVICE MANUAL

(3) Using TDK AC-712 (MA Equivalent) test tape set the bias by recording a 10KHz signal and adjusting "METAL" preset VR201 for both LHC & RHC to give a flat response.

5-4 Dolby B/C/S recording and playback comprehensive frequency characteristics check

(1) Set the Dolby NR switch at "B" position.

(2) Using the three alignment tapes used above record and playback a -25dB Swept signal to check that they are within the limits. (see record limits) Page 18.

(3) Set the Dolby NR switch at "C" position.

(4) Using the three above alignment tapes record and playback a -25dB swept signal to check that they are within the limits. (see record limits) Page 18.

(5) Set the Dolby NR switch at "S" position.

(6) Using the three above alignment tapes record and playback a -25dB swept signal to check that they are within the limits. (see record limits) Page 18.

Exploded View of Mechanism

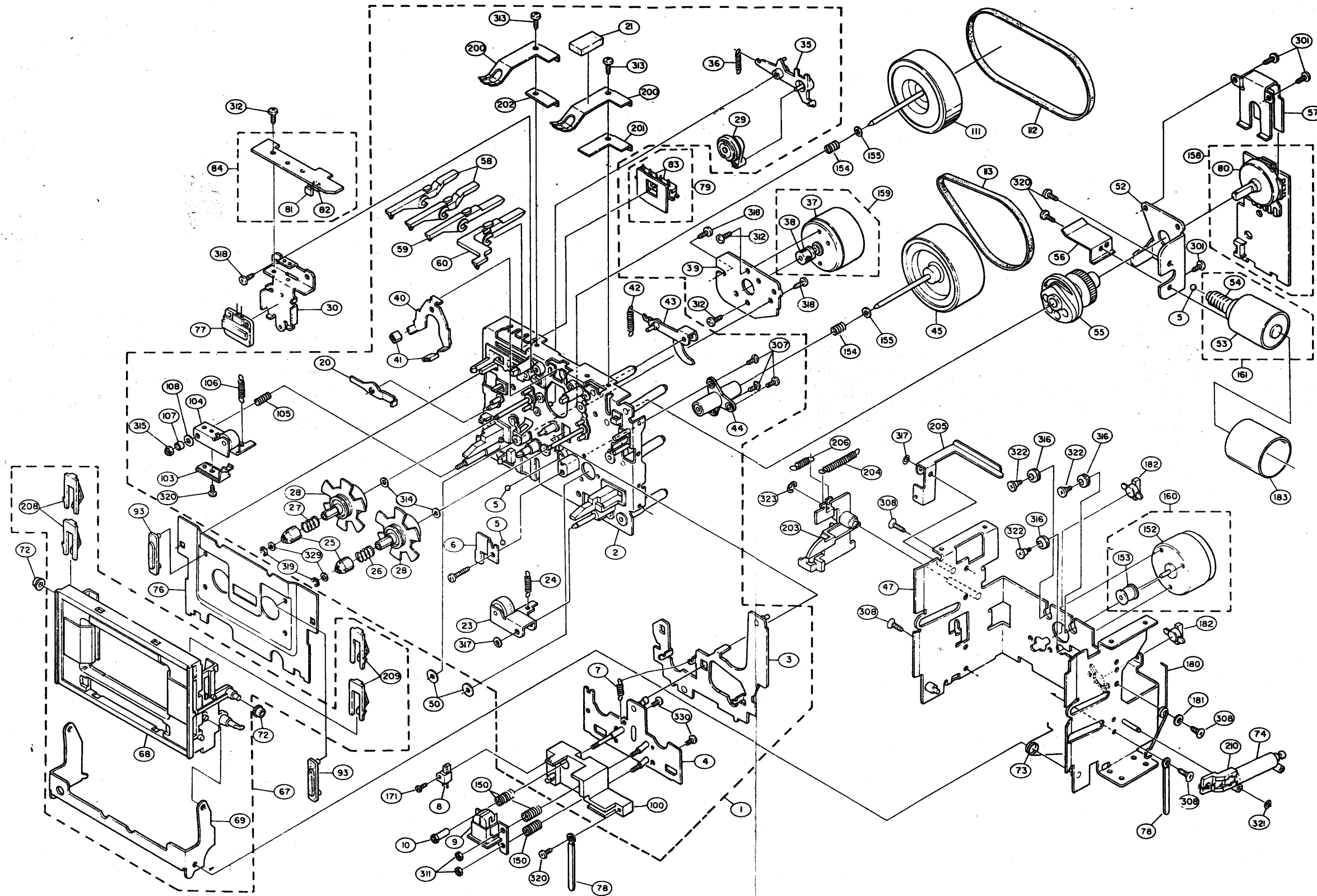

Frequency Response Limits

1. Noise Reduction Circuit Limits

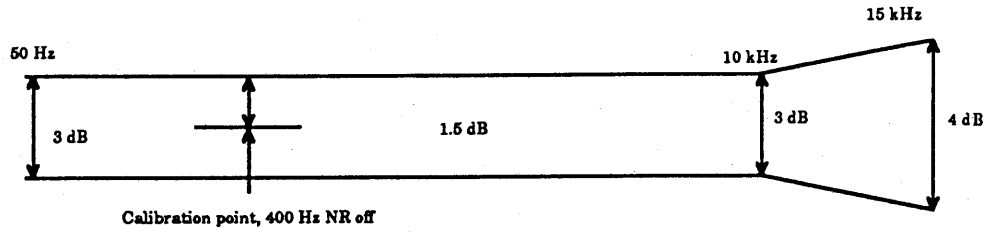

2. Record/Play Response at Monitor/Line Output

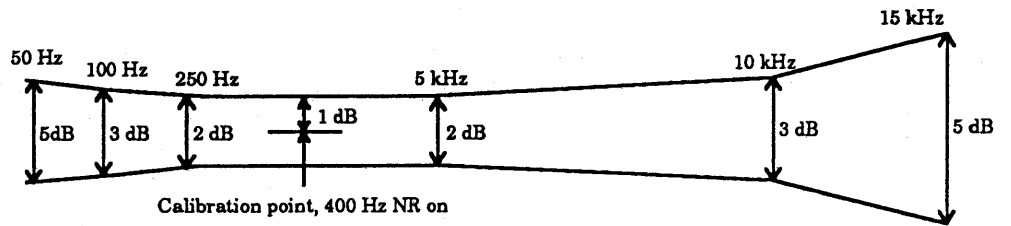

3. Playback Response to IEC Standard Tape

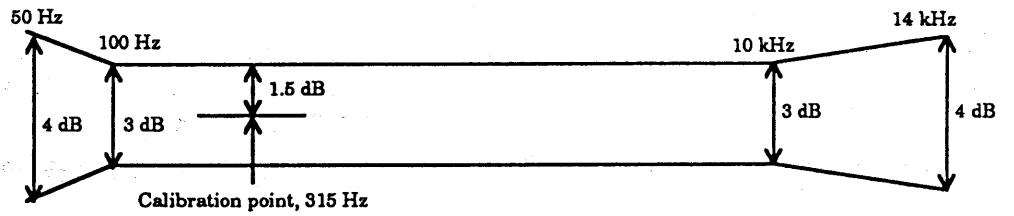

Dolby noise reduction system manufactured under license from Dolby Laboratories Licensing Corporation 'Dolby' and double-D symbol are trademarks of Dolby Laboratories Licensing Corporation.

D100 SERVICE MANUAL

Adjustment & Setup Procedure

ITEM	SIGNAL SOURCE	OUTPUT CONNECTION	MODE	MEASUREMENT ADJUSTMENT	REMARKS
SET BALANCE TRIMPOT	ADJUST LINE IN TO GIVE 388mV ON TP1 DOLBY B/C CARD @400Hz (input level between 80 to 100mv)	TP2 DOLBY B/C PCB SEE SECTION 5 (page 16)	DOLBY "OFF"	VR104 POT PCB	REC "B/C/O" CARD ADJUST VR104 GIVE 388mV ON TP1
SET REC DOLBY S GAIN	LEVEL AS FOUND ABOVE LINE IN 400Hz	TEST POINT ON EACH OF THE TWO DOLBY-S RECORD PCB'S SEE SECTION 5 PAGE 16	DOLBY "OFF"	VR1 ON EACH OF THE "S" PCB	REC "S" CARDS ADJUST VR1 TO GIVE 388mV ON DOLBY-S TEST POINTS
METER CALIBRATION FUNCTION	LEVEL AS FOUND ABOVE LINE IN 400Hz	TAPE DECK METER	DOLBY "OFF"	VR1 VR3 CAL METER PCB	ADJUST SO THAT THE 0dB SEGMENT OF METER IS FULL ON
SOURCE FREQUENCY RESPONSE	LEVEL AS FOUND ABOVE 20Hz-20kHz LINE IN	LINE OUT	SOURCE	CHECK	CHECK RESPONSE TO PLAYBACK LIMITS PAGE 19
MPX RESPONSE	LEVEL AS ABOVE 19kHz	LINE OUT	MPX ON	CHECK	READING MUST BE LESS THAN -35dB @ 19kHz
CROSSTALK (source)	LHC ONLY RHC "OFF"	RHC LINE OUT	SOURCE MPX OFF	CHECK	READING MUST BE LESS THAN -70dB @ 1kHz & -50dB @ 20kHz
HEAD HEIGHT	----- SEE RECORD / PLAYBACK SECTION 3 -----				
TAPE SPEED	3KHZ TEST TAPE A.BEX TCC-110	LINE OUT SEE SECTION 3 (page 16)	PLAY	REGULATOR BACK SIDE OF CAPSTAN MOTOR	PLAY HALF WAY POINT OF TAPE ADJUST TO GIVE 3KHZ +/-6HZ
WOWFLUTTER	3KHZ TEST TAPE A.BEX TCC-110	LINE OUT	PLAY	CHECK	USE (JIS) METHOD MAX LIMIT OF 0.04% WRMS
PLAYBACK TORQUE	----- SEE SECTION 7 & 8 (page 12-13) -----				
AZIMUTH	A.BEX TCC-153 AZIMUTH 10 KHZ TAPE	LINE OUT SECTION 4-3 (page 15)	PLAY	AZIMUTH ADJUSTMENT NUT	ADJUST NUT SO THAT A AND B IN THE LISSAJOUS FIGURE ARE AT MAX & MIN LESS THAN +/-25 DEG
DOLBY PB LEVEL	A.BEX TCC-130 200nWb/m DOLBY TAPE LEVEL	TP1 & TP2 PB DOLBY B/C/OFF SECTION 4 (page 16)	PLAY DOLBY OFF	VR1 VR101	PB "B/C/OFF" CARD ADJUST TO GIVE 388mV ON TP1 & TP2
SET PB DOLBY S GAIN	A.BEX TCC-130 200nWb/m DOLBY TAPE LEVEL	TP ON EACH PB DOLBY-S PCB SECTION 4 (page 16)	DOLBY OFF	VR1 ON EACH PCB	PB "S" CARDS ADJUST VR1 TO 388mV ON TP
B/C/S. NR SWITCHING	A.BEX TCC-130 200nWb/m DOLBY TAPE LEVEL	MOTHER PCB TPL27 (Lch) TPR27 (Lch)	PLAY DOLBY B/C/S	CHECK	SWITCH DOLBY CHECK LEVEL ON TPL27 & 27TPR STAY CONSTANT WITHIN +/-0.5db
PLAYBACK 120uS FREQUENCY RESPONSE	A.BEX TCC-161B 120uS FREQUENCY RESPONSE TAPE	LINE OUTPUT SECTION 4-2 (page 16)	PLAY	CHECK	CHECK PLAYBACK RESPONSE TO LIMITS
PLAYBACK 70uS FREQUENCY RESPONSE	A.BEX TCC-261B 70uS FREQUENCY RESPONSE TAPE	LINE OUTPUT SECTION 4-2 (page 16)	PLAY	CHECK	CHECK PLAYBACK RESPONSE TO LIMITS

D100 SERVICE MANUAL

ITEM	SIGNAL SOURCE	OUTPUT CONNECTION	MODE	MEASUREMENT ADJUSTMENT	REMARKS
PLAYBACK NOISE	C-0 TAPE 120uS	LINE OUTPUT	PLAY DOLBY OFF	CHECK	READING MUST BE LESS THAN -46dBV (CCIR) 120uS
MINIMUM NR EFFECT	C-0 TAPE 120uS	LINE OUTPUT	DOLBY B C S	CHECK - - -	MIN NR EFFECT -57dBV (CCIR) -66dBV (CCIR) -69dBV (CCIR)
BIAS OSCILLATOR FREQUENCY SET UP	NO INPUT	TP2 SEE SECTION 5 (page 16)	RECORD	OSCILLATOR COIL L202	ADJUST TO GIVE 105KHZ WHEN WARM
DOLBY RECORD AMP GAIN	LINE INPUT ADJUST TO GIVE 338MV ON REC DOLBY CARDS	TP1 TP2 PB DOLBY CARDS SEE SECTION 5 (page 16)	RECORD DOLBY OFF	VR2 VR102	PB *B/C/OFF CARD ADJUST TO GIVE 388mV ON TP1 & TP2. SWITCH BETWEEN TAPE & SOURCE & LEVEL SHOULD BE THE SAME
RECORD \ PLAYBACK RESPONSE	SEE SECTION 5 (page 16)				
CHANNEL SEPARATION (RECORD /PLAYBACK AUDIO CIRCUITS)	LHC ONLY @ DOLBY LEVEL RHC *OFF*	RHC LINE OUT	TAPE RECORD	CHECK	READING MUST BE LESS THAN -45dB @ 1kHz & -20dB @ 20kHz
HEADPHONE OUTPUT	LINE INPUT ADJUST TO GIVE 338MV ON REC DOLBY CARDS FREQ @ 1kHz	HEADPHONE OUTPUT	SOURCE	CHECK	CHECK LEVEL FOR 1.8 TIMES LEVEL ON LINE OUT. USE 600 OHM LOAD
THD @ 0dB	LINE INPUT TO GIVE 338MV ON REC DOLBY CARDS FREQ @ 1kHz	LINE OUT	RECORD	CHECK	CHECK THAT THE TOTAL HARMONIC DISTORTION IS LESS THAN 1.5% ALL TAPE TYPE
MAXIMUM OUTPUT LEVEL	LINE INPUT TO GIVE 338MV ON REC DOLBY CARDS FREQ @ 300Hz	LINE OUT	RECORD TYPE I TYPE II TYPE IV	CHECK	MOL LIMITS LEVEL +6dB +3dB +5dB
ERASE CHECK	INCREASE SIGNAL BY +6dB FROM DOLBY LEVEL AS FOUND ABOVE FREQ @ 125Hz	LINE OUT VIA 125Hz BAND PASS FILTER BETWEEN LINE OUT & METER	RECORD TYPE IV	CHECK WHEN ERASED TAPE IS PLAYED BACK THE 125Hz SIGNAL IS -60dB	RECORD THE 125Hz SIGNAL THEN REWIND & RECORD SILENCE OVER RECORDED TONE.
CALIBRATION SYSTEM SET UP	CASSETTE DECK CALIBRATION SYSTEM OSCILLATOR	CASSETTE DECK CALIBRATION METER	CAL/REC MODE	HFLF PRESETS	ADJUST HFLF PRESET SO THAT THE 0dB SEGMENT OF METER IS FULL ON
CALIBRATION SYSTEM RANGE CHECK	AS ABOVE	AS ABOVE	CAL/REC MODE	CHECK RANGE BIASICAL POTS. CHECK WITH DECK METERS	POT RANGE BIAS : +/-4dB CAL : +/-6dB
CHECK CAL RETURN	-	-	CAL \ REC MODE	CHECK	PUT IN CAL MODE / RECORD THEN PRESS CAL BUTTON AND CHECK TAPE RETURNS TO START POINT
CHECK MUSIC SEARCH	PRE RECORDED MUSIC CASSETTE (WITH 5 SEC GAPS)	-	PLAY / FF	CHECK	PRESS FF & PLAY TAPE. SHOULD STOP AT 5 SEC GAP & PLAY THE TRACK.

Dolby encode characteristics for B/C/S NR

The Dolby cards may be tested in the Cassette Deck (encode mode only) by using the Line input and test points on Dolby cards.

Input level dBr	100	200	500	1K	2K	5K	10K	20K
0	0.0	0.0	0.0	0.0	0.1	0.3	0.4	0.7
-10	0.0	0.4	0.8	1.0	0.9	1.0	1.1	1.2
-20	0.0	0.5	2.6	4.2	4.3	3.2	2.6	2.7
-30	0.0	0.6	2.9	6.1	8.5	8.2	6.5	6.5
-40	0.0	0.6	2.9	6.3	8.9	10.3	10.4	10.3

Table B-type NR encode characteristics.

Frequency (Hz)

Input Level dBr	100	200	500	1K	2K	5K	10K	15K
0	0.2	-0.1	0.0	-0.3	-1.0	-2.3	-3.5	-6.3
-10	0.9	1.5	1.7	1.5	0.6	-0.6	-1.4	-3.3
-20	2.7	5.3	6.3	5.9	4.6	2.9	2.6	1.5
-40	2.9	8.1	15.6	16.2	14.7	13.5	13.6	12.2
-60	2.9	8.1	16.2	19.6	20.7	20.4	19.2	15.0

Table C-type NR encode characteristics.

Frequency (Hz)

Input Level dBr	20	50	100	200	500	1K	2K	5K	10K	20K
0	-6.5	-2.0	-0.1	0.1	0.0	0.0	-0.3	-2.4	-5.2	-8.4
-20	-1.4	2.0	6.2	7.8	7.2	6.6	5.9	4.1	2.9	0.8
-40	2.5	7.4	10.9	15.0	17.1	17.2	16.6	15.4	14.7	10.1
-60	2.5	7.5	11.0	15.2	19.8	23.3	23.5	22.8	21.5	11.6

Table S-type NR encode characteristics minimum levels respectively.

See page 18 for Noise Reduction Circuit Limits. * Note: 388mV = 0 dBr *

Change of Mains Voltage

WARNING - The unit must be unplugged from the mains supply when changing the wiring or the mains fuses since the fuse is at mains potential even with the unit switched off.

The D100 has a multi voltage transformer so the same transformer can be used for 240V, 220V and 120V by moving two of the three wires, (orange, yellow or brown) and changing the fuse rating as necessary. 100V use requires a special single voltage transformer (Part No 7AQ01) which is wired in the same way as 240V unit, but a 1.0A ANTI-SURGE FUSE must be fitted.

Referring to the table below and the transformer pcb, the colour of the wire in the shaded box determines the mains voltage i.e. orange for 240V. The other two wires go in the holes marked "Spare Wires". The black wire does not move.

**240V WIRING (500mA ANTI-SURGE FUSE)
100V WIRING (1.0A ANTI-SURGE FUSE)**

■ BROWN SPARE WIRES (Not on 100V) ■ YELLOW	■ BLACK
■ ORANGE	240V ORANGE

220V WIRING (500mA ANTI-SURGE FUSE)

■ BROWN SPARE WIRES ■ ORANGE	■ BLACK
■ YELLOW	220V YELLOW

120V WIRING (1.0A ANTI-SURGE FUSE)

■ YELLOW SPARE WIRES ■ ORANGE	■ BLACK
■ BROWN	120V BROWN

Test Points on Mother PCB

Test Points on Mother PCB		Typical Voltage
0	Supply star Earth (Ground)	EARTH
1	Bias oscillator supply	3.3 VDC (Type I tape ONLY) Type II & IV depend on setting
2	Bias erase head voltage	25VAC pk-pk (10X Probe) @105kHz (Type I tape ONLY) Type II & IV depend on setting
3	Bias record output	55VAC pk-pk (10X Probe) @105kHz (Type I tape ONLY) Type II & IV depend on setting
4	Not used	---
5	Mute circuit supply	3.1 VDC (IC internal ref)
6	Mute circuit output	LOW = Relay ON (0.8 VDC)
7	Mute circuit R/C delay	1.3 VDC when TP6 is "LOW"
8	AC Supply from transformer	14VAC (Quiescent)
9	AC Supply from transformer	14VAC (Quiescent)
10	Positive unregulated supply	+21VDC (Quiescent)
11	Negative unregulated supply	-21VDC (Quiescent)
12	+15 volt regulated supply (Z206)	+15VDC (+/-0.7v)
13	-15 volt regulated supply (Z209)	-15VDC (+/-0.7v)
14	+6 volt regulated supply (Z208)	+6VDC (+/-0.7v)
15	-6 volt regulated supply (Z207)	-6VDC (+/-0.7v)
16	Mute relay supply	+21VDC (Relay ON)
17	Mute circuit AC sense	-12.7VDC (Relay ON)
18	Mute circuit status (on/off)	-0.4VDC = ON (+voltage = OFF)

Test Points on Mother PCB

Audio test Points on Mother PCB Test point numbers are for L & R channels ie: shown as TPL19 or TPR19 etc.	
19	Line input to filter / MPX (SKB6)
20	Line filter output (Z6 / Z106)
21	Line filter / MPX switched output
22	Source output (Dolby-S op-amp on encode PCB's)
23	Dolby-S "ENCODE" output
24	Dolby-B-C-OFF "ENCODE" output
25	Dolby "ENCODE" swiching output (CMOS switches Z201 & Z202)
26	Record 70uS EQ output
27	Dolby "DECODE" switching output (CMOS switches Z201 & Z210)
28	Record head total bias current
29	Record amplifier input (SKB2)
30	Record amplifier output (Z204)
31	1st stage playback amplifier output (op-amps Z1 & Z101)
32	2nd stage Playback amplifier / Eq output (op-amp Z2 & Z102)
33	Playback 70uS Eq output
34	Dolby "DECODE" input
35	Dolby-S "DECODE" output
36	Dolby-B-C-(thor) "DECODE" output
37	Input to line output amplifier (SKB4)
38	Line output amplifier (Z5 & Z105)

D100 Circuit Diagrams

No	Title of circuit	Circuit No
1	Control Board	C02_0044.001
2	Display Board	C02_0045.001
3	Dolby B/C Board	C02_0047.001
4	Dolby-S Board	C02_0046.001
5	Calibration Board	C02_0048.003
Mother Board circuits		
6-1	PSU & Mute circuit	C02_0043.101
6-2	Line input filter, MPX & decode Dolby switching	C02_0043.201
6-3	Record amp & Bias oscillator / Level control	C02_0043.301
6-4	Playback amplifier & Dolby encode switching	C02_0043.401
6-5	Line output amplifier & H-Phones amplifier	C02_0043.501

PARTS LIST OF MECHANISM

Ref. No.	Part No.	Part Name	Remarks
1	411 0858 106	MECHA BASE (G) ASSY	
2	411 0679 301	MECHA BASE ASS'Y	
3	431 0242 101	HEAD SLIDER ASSY	
4	431 0282 006	HEAD PLATE ASSY	
5	425 8011 009	STEEL BALL D3	
6	431 0240 006	BALL GUIDE PLATE	
7	463 8230 002	SPRING	
8	391 8826 001	ERASE HEAD	
9	391 0267 008	REC/P.B HEAD	
10	443 8671 001	SPECIAL NUT	
11	445 8028 009	CORD HOLDER	
20	433 8224 208	STOPPER	
21	461 0154 083	CUSHION	
23	433 8194 105	PINCH ROLLER ARM ASSY	
24	463 8231 108	SPRING	
25	421 0446 104	REEL DRIVER	
26	463 0522 103	SPRING	
27	463 0438 003	SPRING	
28	421 8401 109	REEL DRIVE WHEEL	
29	433 0449 201	IDLER ARM (B) GEAR ASSY	
30	441 0692 101	LAMP HOLDER	
35	433 8236 306	IDLER ARM(A)ASSY	
36	463 8271 003	SPRING	
37	217 0161 000	REEL MOTOR	
38	421 8403 000	PULLEY	
39	441 0850 008	DC MOTOR FIX PLATE	
40	431 0241 005	BLAKE	
41	461 8217 106	BLAKE SHOE	
42	463 8234 105	SPRING	
43	433 8232 300	BLAKE ARM ASSY	
44	443 8648 302	METAL HOUSING ASSY	
45	421 0389 106	FLY WHEEL ASSY	
47	441 0837 102	MECHA STAY ASSY	
50	477 0090 074	WASHER	
52	411 8966 305	CAM MOTOR HOLDER	
53	217 0168 003	DC MOTOR	
54	424 8025 607	WORM GEAR	
55	424 8027 401	CAM	
56	414 0414 109	OIL FENCE	
57	442 8018 308	ENCLODE BLAKET	
58	433 0493 105	HOLE SENSOR (A)	
59	433 0494 104	HOLE SENSOR (B)	
60	433 0495 103	HOLE SENSOR (C)	
67	GEN0410	CASSETTE BOX SUB ASSY	

Ref. No.	Part No.	Part Name	Remarks
68	103 1209 303	CASSETTE BOX	
69	433 0459 411	CASSETTE BOX HOLDER	
72	431 8097 002	COLLAR	
73	463 0524 101	BOX SPRING	
74	469 8013 104	AIR DUMPER	
76	144 1859 107	ESC. PLATE	
77	393 9179 012	LN0105YP4(YW)	
78	445 8028 009	CORD HOLDER	
79	2U- 1515 1	HOLE SENSOR PWB ASSY	
80	212 3331 308	ROTARY ENCODER	
81	393 9178 000	LN25RCP	
82	393 9026 000	PN150	
83	212 4665 002	SLIDE SWITCH	
84	2U- 1515 2	REEL PULSE PWB ASSY	
90	103 1221 310	STABILIZER	
91	463 0609 107	" SPRING	
92	461 0491 209	" PAD (A)	
93	461 0488 005	" PAD (B)	
100	443 0903 207	HEAD BLOCK	
103	433 0407 308	TAPE GUIDE	
104	433 0408 006	PINCH ROLLER ARM (L) ASSY	
105	463 0414 101	SPRING	
106	463 0480 009	SPRING	
107	443 0539 008	WASHER	
108	477 0240 002	WASHER	
111	421 0538 106	CAPSTAN WHEEL ASSY	
112	423 8026 108	BELT	
113	423 8030 110	BELT	
150	463 0162 009	SPRING	
152	217 0162 009	CAPSTAN MOTOR	
153	421 8383 007	MOTOR PULLEY	
154	463 0618 004	FLY WHEEL SPRING	
155	477 0090 016	WASHER	
158	4U- 1831 -4	MECHA.PWB ASSY	
159	DRO 4A04	REEL MOTOR SUB ASSY	
160	DCO 7A02	CAPSTAN MOTOR SUB ASSY	
161	DCO 6A04	CAM MOTOR SUB ASSY	
171	471 1822 010	CAMERA SCREW 2 x 8	
180	463 0628 104	DUMPER SPRING	
181	475 1003 006	WASHER	
182	461 0473 201	THRUST COVER	
183	443 0948 000	SHIELD COVER	
200	463 8829 303	CASSETTE SPRING	
202	442 8154 107	CP SUPPORT	
203	441 0897 003	SPRING GUIDE	
204	433 8269 506	HOOK	

Ref. No.	Part No.	Part Name	Remarks
205	412 8829 303	ANGLE	
206	463 0561 009	SPRING	
208	103 8243 401	CASSETTE SUPPORT (L)	
209	103 8243 414	CASSETTE SUPPORT (R)	
210	433 8271 400	DUMPER GUIDE	
301	473 7002 005	3 x 6 CBTS(S)-Z	
307	471 3202 010	2.6 x 5 CBS	
308	471 7021 002	2.6 x 6 CFT(S)	
310	471 3802 025	2.6 x 14 CBS	
311	475 6020 000	2NUT	
312	471 3802 012	2.6 x 3 CBS-Z	
313	473 7001 006	2.6x5 CBTS(S)-Z	
314	477 0265 016	WASHER	
315	477 0269 009	NYLON NUT	
316	462 0086 015	MOTOR CUSHION	
317	475 1121 108	SLIT WASHER	
318	473 7500 002	3 x 6 CBTS(P)-z	
319	476 1114 008	1.5 E. RING	
320	471 3801 039	2 x 3 CBS-Z	
321	475 1120 109	SLIT WASHER	
322	477 0294 003	SPECIAL SCREW	
323	476 1003 009	3 E.RING	
329	475 1139 103	2.1 WASHER	

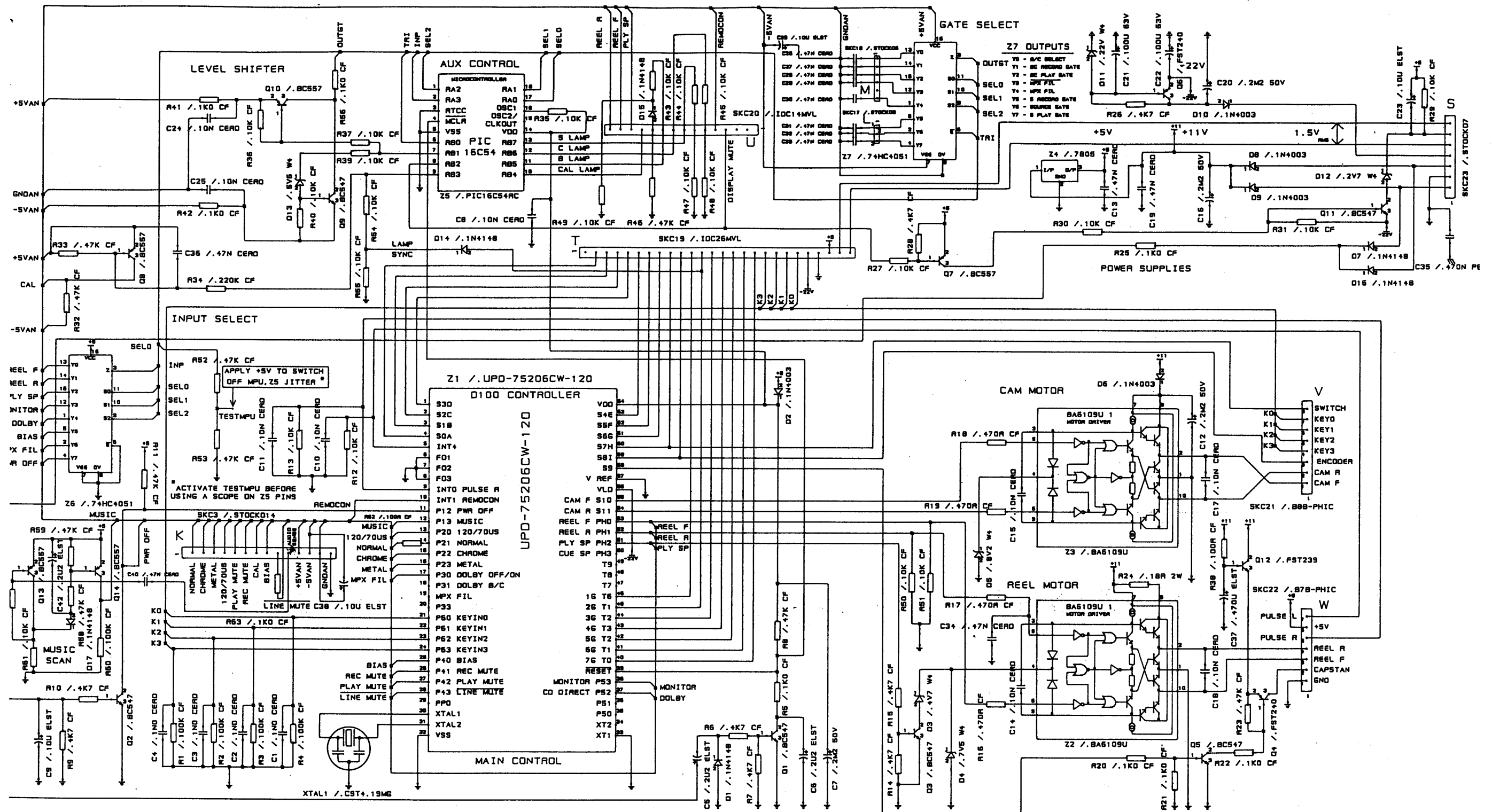

FILE NAME	CONTROL	1E	6-NOV-1991	
DRAWN BY	S. BLANDFORD	ISS	DATE	ECN NO.
DATE DRAWN	1-OCT-1991	TITLE	D100 CONTROL BOARD	
SHT.	1	DF.	1	ORG NO. CO2 0044
SERVICE MANUAL DRW. NO. HO4/ 0015 SHEET 1 OF 1				
ARCAM. A & R CAMBRIDGE LTD, CB5 9PB				

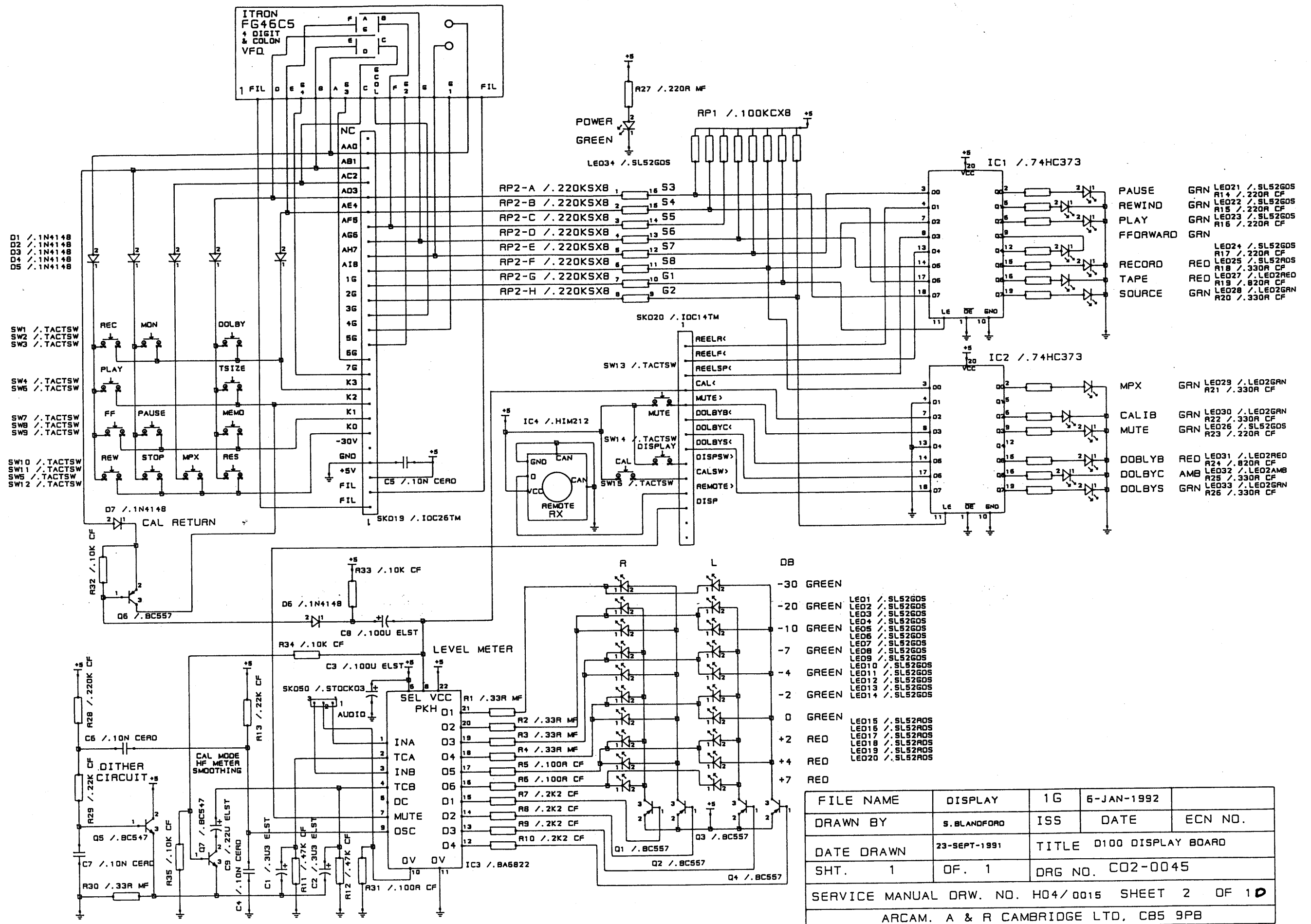

FILE NAME	DISPLAY	1G	6-JAN-1992	
DRAWN BY	S. BLANDFORD	ISS	DATE	ECN NO.
DATE DRAWN	23-SEPT-1991	TITLE D100 DISPLAY BOARD		
SHT.	1	OF.	1	DRG NO. CO2-0045
SERVICE MANUAL DRW. NO. H04/0015 SHEET 2 OF 10				
ARCAM. A & R CAMBRIDGE LTD, CB5 9PB				

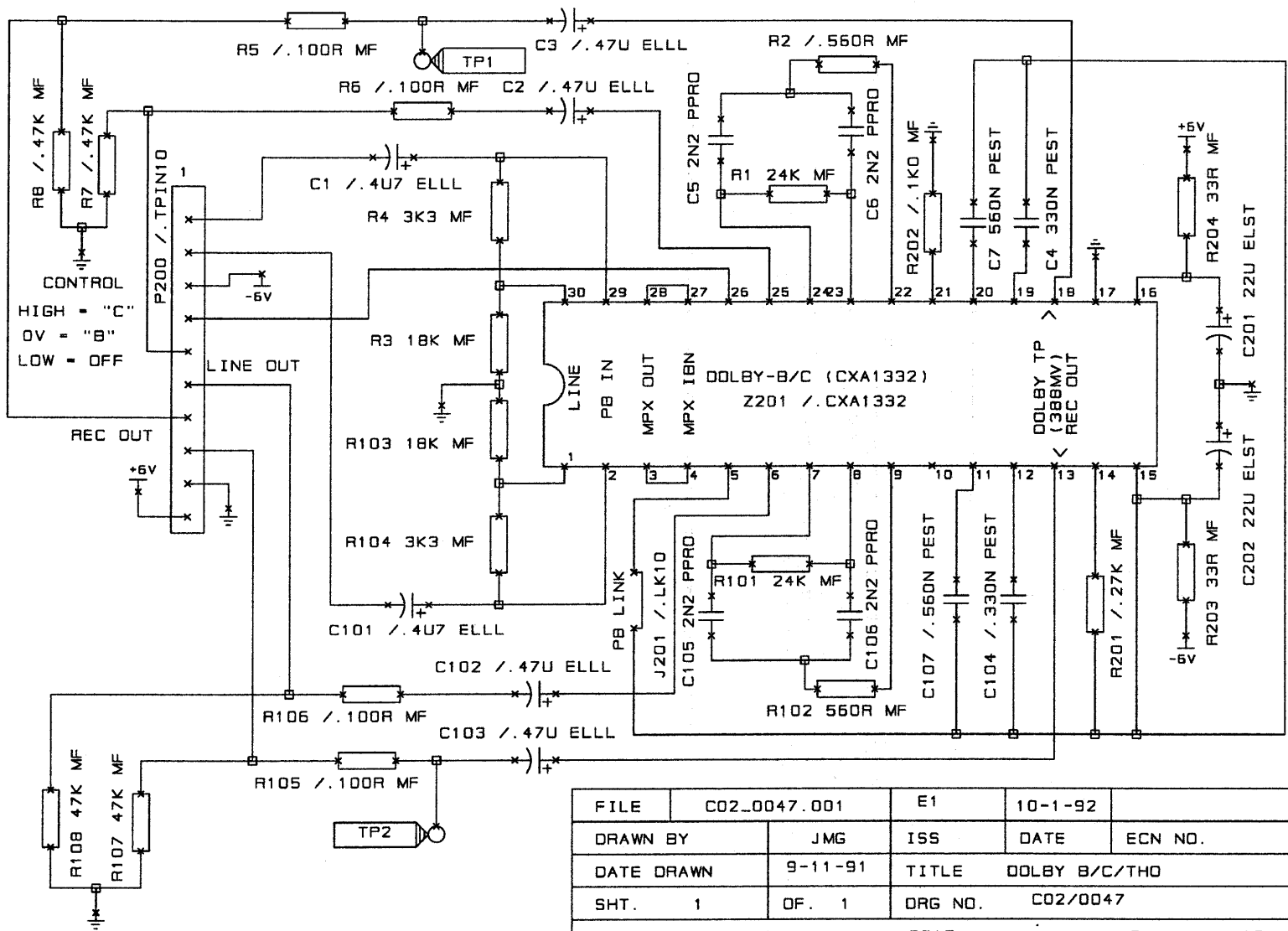

FILE	CO2_0047.001	E1	10-1-92	
DRAWN BY	JMG	ISS	DATE	ECN NO.
DATE DRAWN	9-11-91	TITLE	DOLBY B/C/THO	
SHT.	1	OF.	1	ORG NO. CO2/0047
SERVICE MANUAL DRW NO.	HD4/0015	SHT.	3	OF 10
ARCAM. A & R CAMBRIDGE LTD, CB5 9PB				

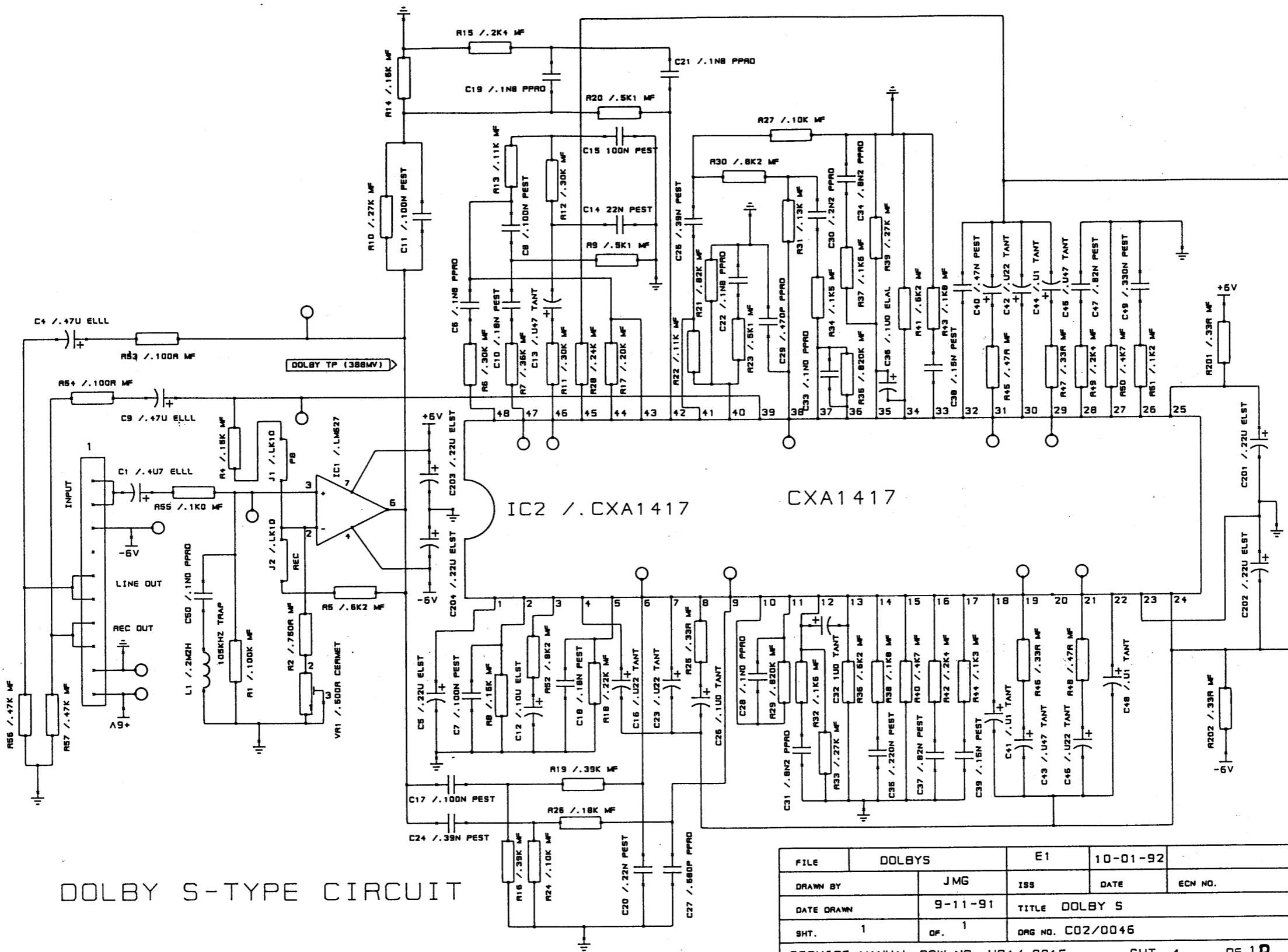

DOLBY S-TYPE CIRCUIT

PCB FILE : DOL-S3

FILE	DOLBYS	E1	10-01-92	
DRAWN BY	JMG	ISS	DATE	ECN NO.
DATE DRAWN	9-11-91	TITLE	DOLBY S	
SHT. 1	OF 1	DRG NO.	C02/0046	
SERVICE MANUAL DRW NO. H04/ 0015			SHT. 4	OF 10
ARCAM. A & R CAMBRIDGE LTD. CB5 9PB				

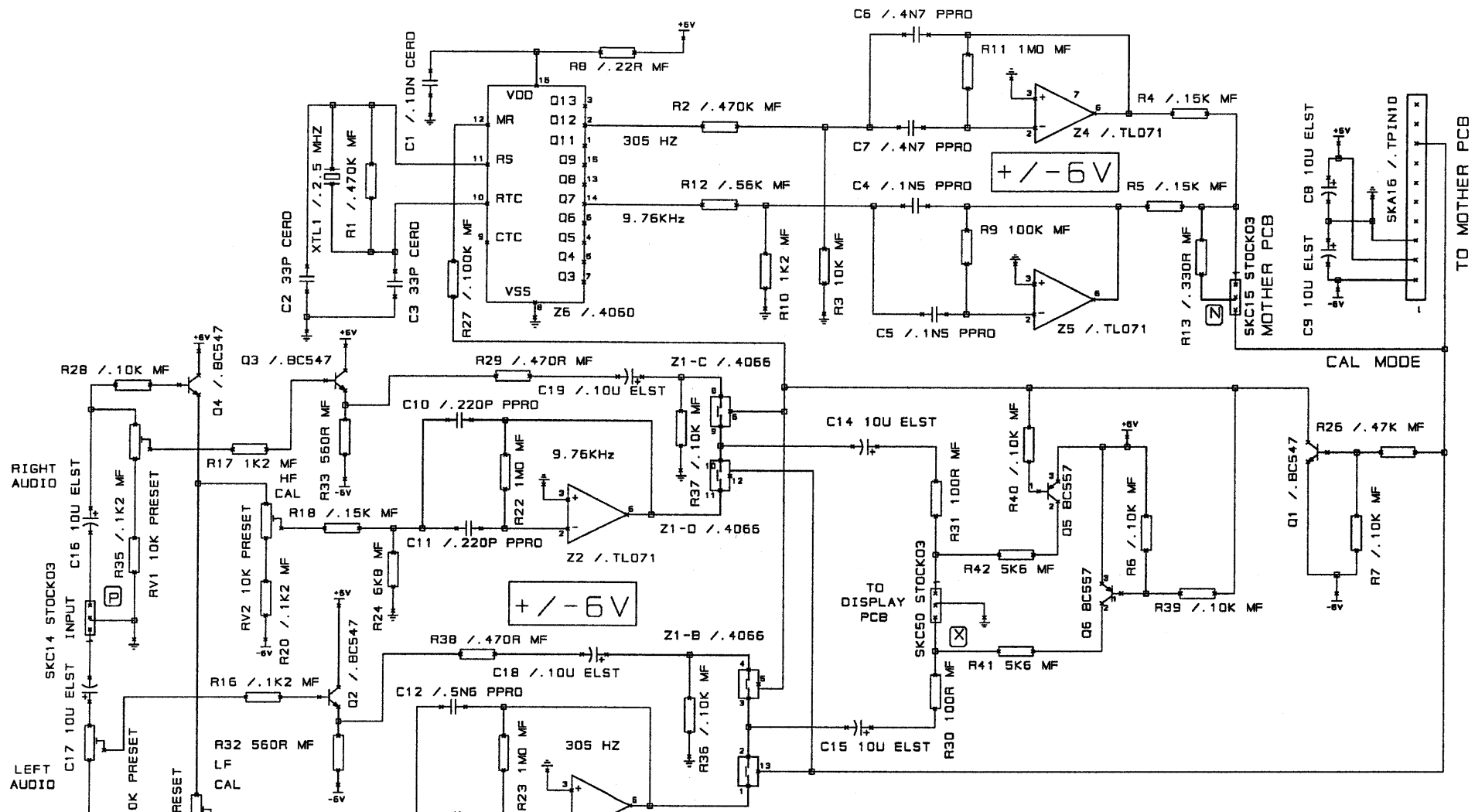

FILE NAME	C02_0048.103	3	4-2-92	92008
DRAWN BY	JMG	ISS	DATE	ECN NO.
DATE DRAWN	2-4-91	TITLE 0100 CASSETTE DECK CALIBRATION CCT		
SHT. 1	OF. 1	DRG NO. C02/0048		
SERVICE MANUAL DRW. NO. H04/0015 SHEET 5 OF 10				
ARCAM. A & R CAMBRIDGE LTD, CB5 9PB				

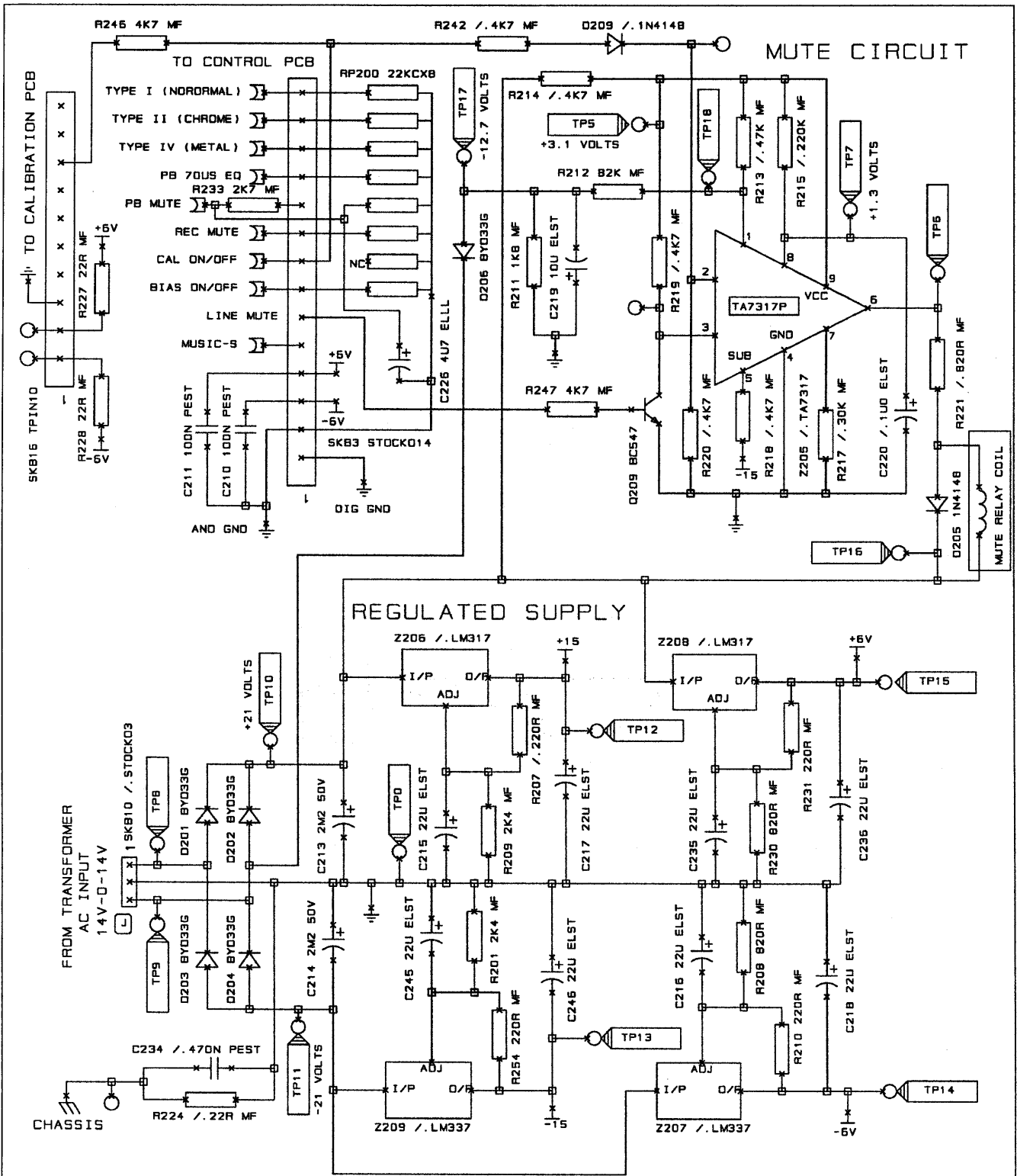

FILE NAME	C02_0048.003	E1	18-2-92	92014
DRAWN BY	JMG	ISS	DATE	ECN NO.
DATE DRAWN	4-4-92	TITLE PSU & MUTE CCT		
SHT.1	OF. 5	DRG NO. C02/0043		
SERVICE MANUAL DRW. NO. H04/0015 SHEET 6 OF 10				
ARCAM. A & R CAMBRIDGE LTD, CB5 9PB				

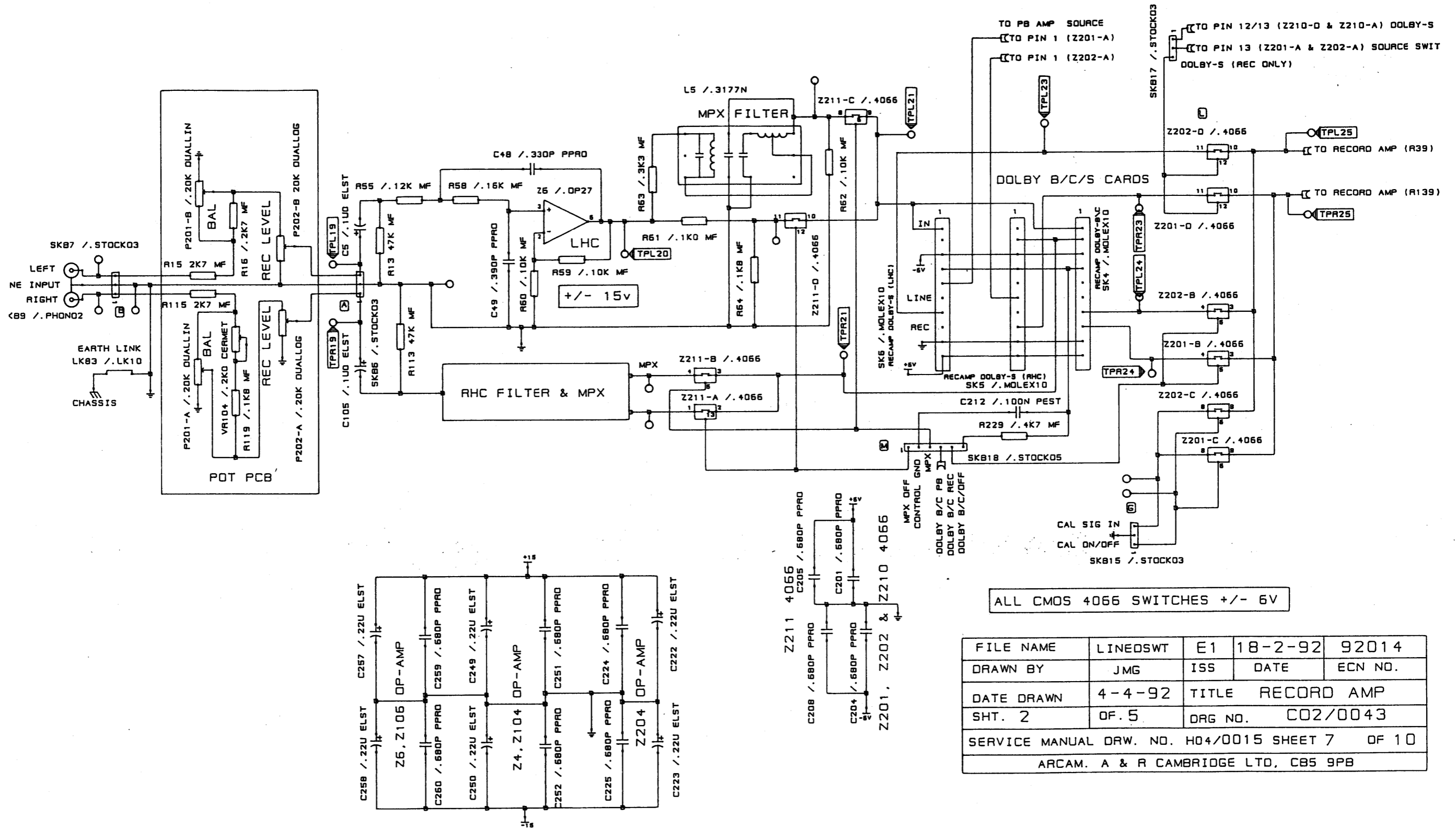

ALL CMOS 4066 SWITCHES +/- 6V

FILE NAME	LINESWT	E1	18-2-92	92014
DRAWN BY	JMG	ISS	DATE	ECN NO.
DATE DRAWN	4-4-92	TITLE RECORD AMP		
SHT. 2	OF 5	DRG NO.	CO2/0043	
SERVICE MANUAL DRW. NO. H04/0015 SHEET 7 OF 10				
ARCAM. A & R CAMBRIDGE LTD, CB5 9PB				

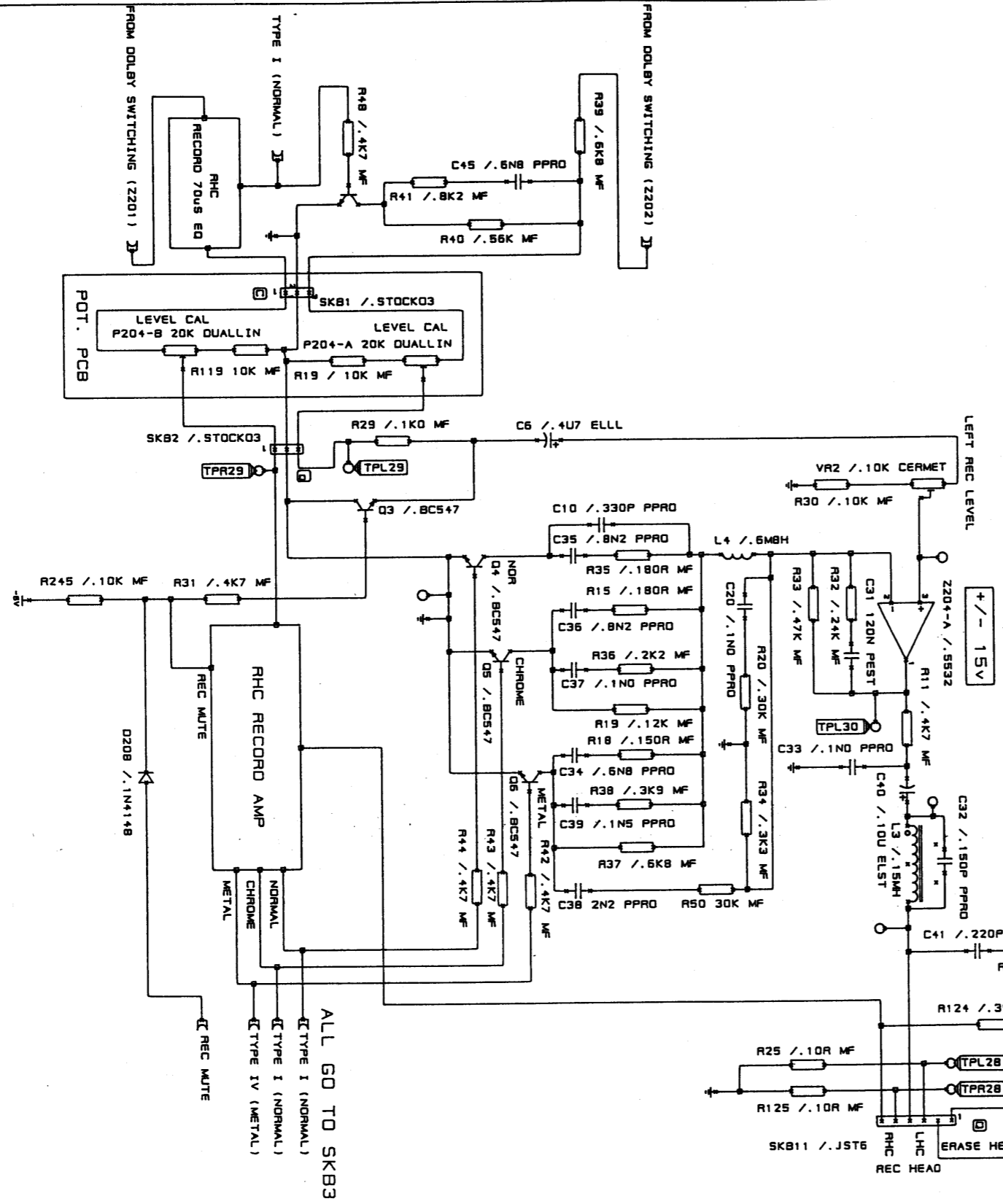
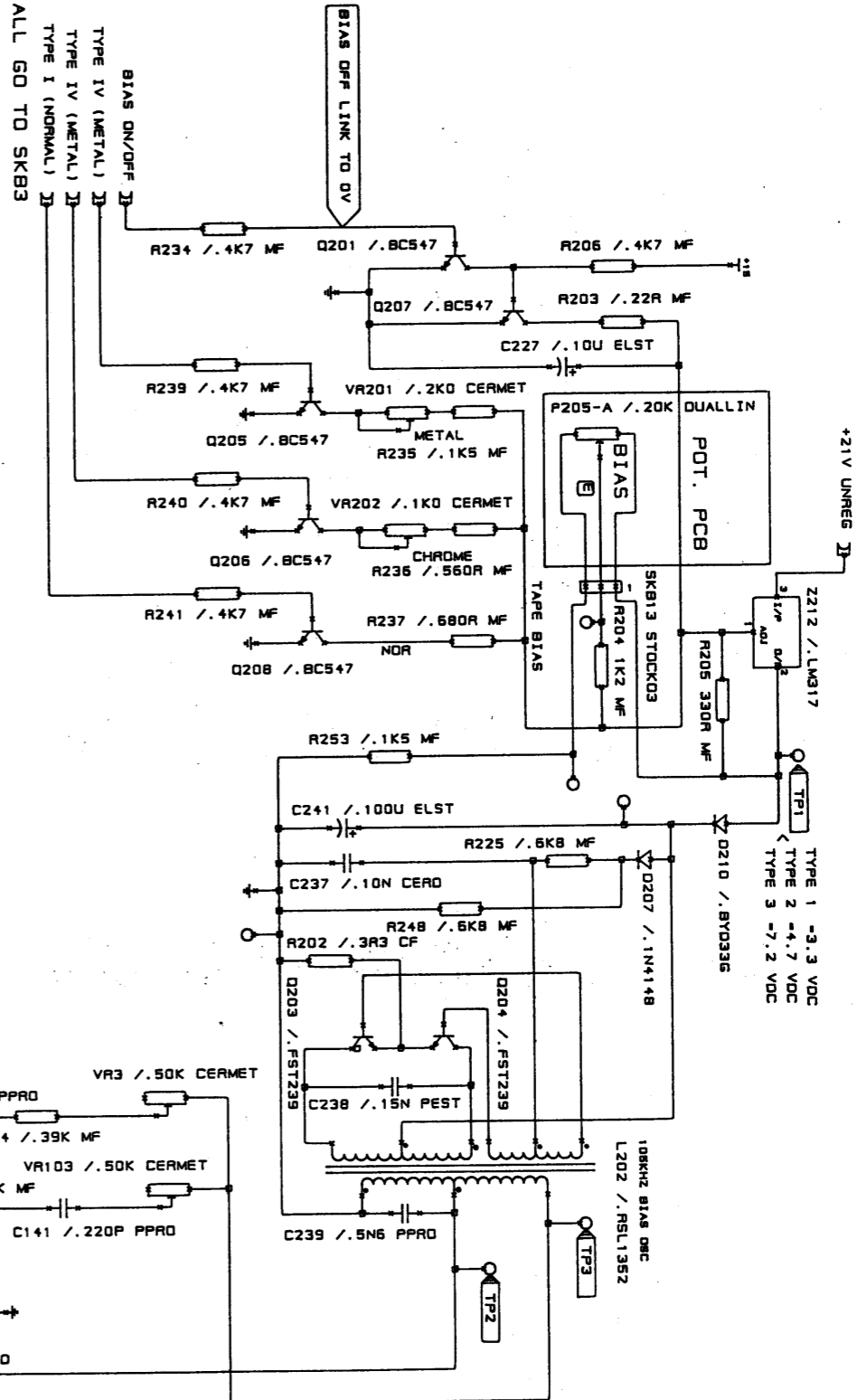

FILE NAME	RECOSC	E1	18-2-92	92014
DRAWN BY	JMG	ISS	DATE	ECN NO.
DATE DRAWN	2-4-92	TITLE	RECORD AMP/BIAS OSC	
SHT. 3	OF. 5	DRG NO.	CO2/0043	
SERVICE MANUAL DRW. NO. H04/ 0015 SHEET 8 OF 10				
ARCAM. A & R CAMBRIDGE LTD. CBS 9PB				

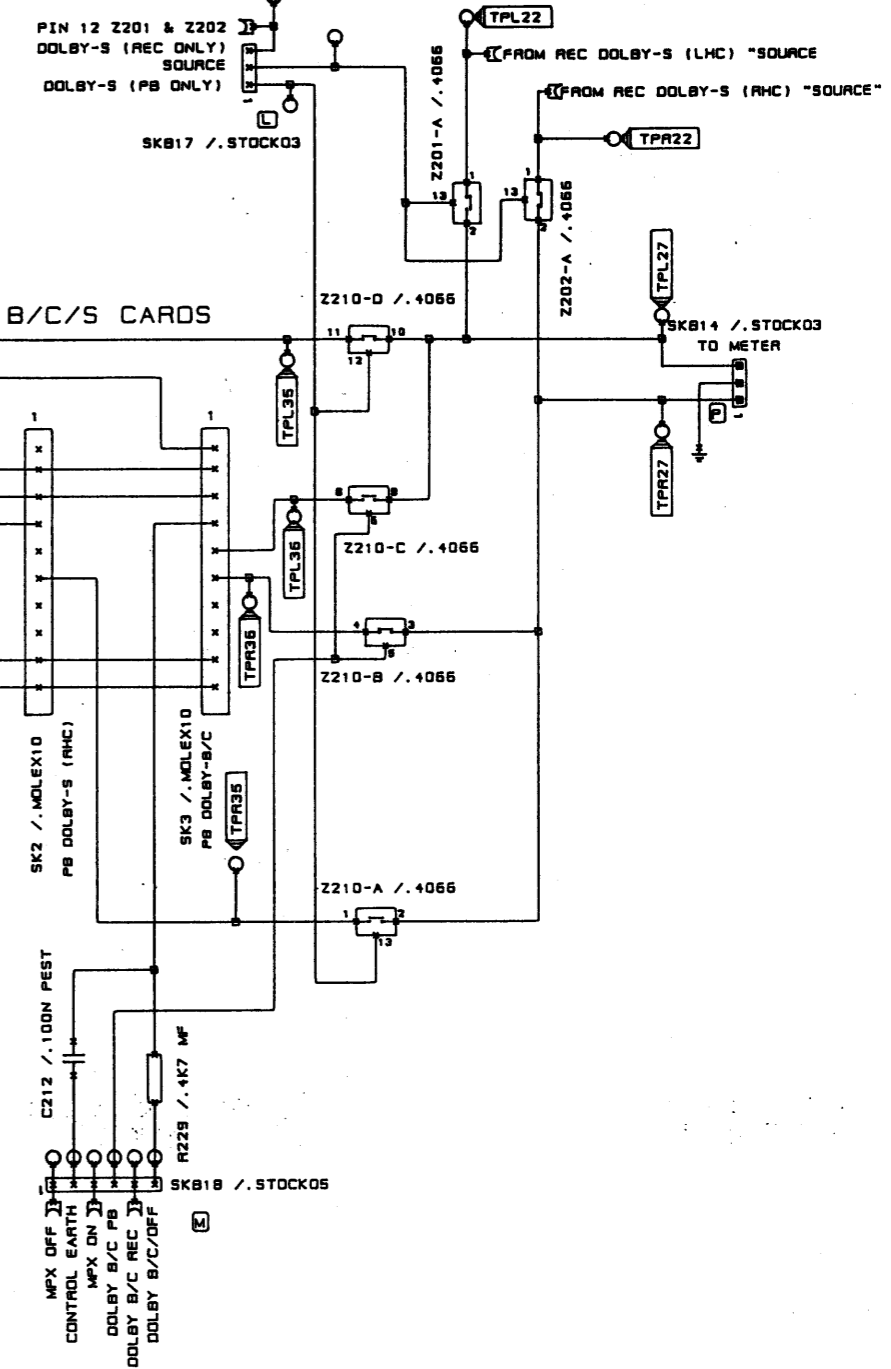
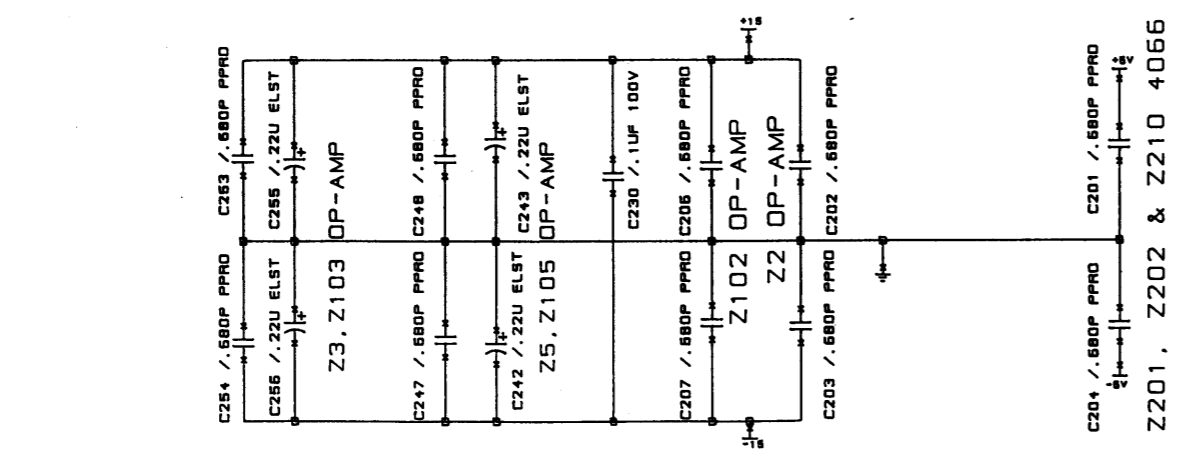
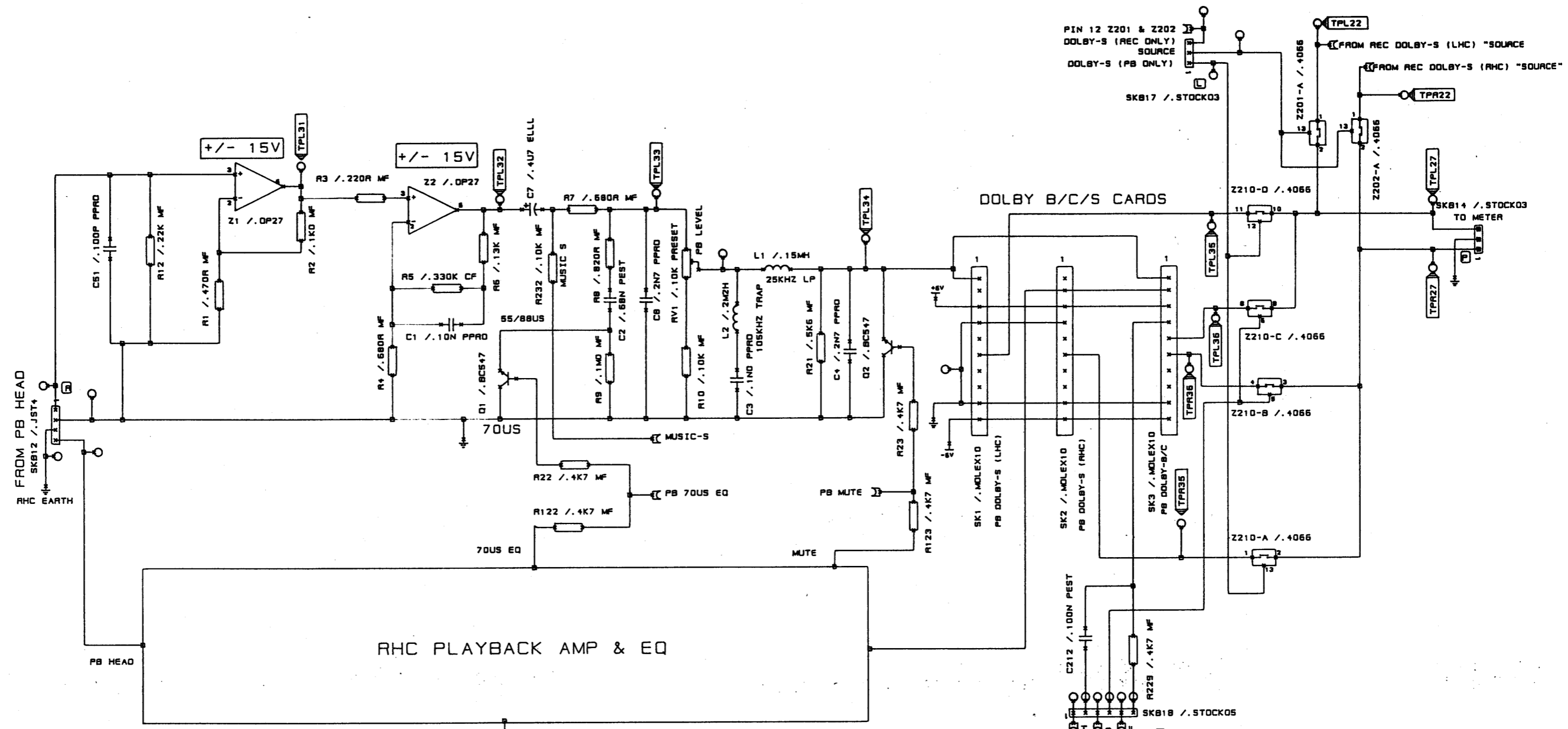

FILE NAME	PBDOLSWT	E1	18-2-92	92014
DRAWN BY	JMG	ISS	DATE	ECN NO.
DATE DRAWN	4-4-92	TITLE PLAYBACK AMP		
SHT. 4	OF. 5	DRG NO. C02/0043		
SERVICE MANUAL DRW. NO. H04/ 0015 SHEET 9 OF 10				
ARCAM. A & R CAMBRIDGE LTD, CB5 9PB				

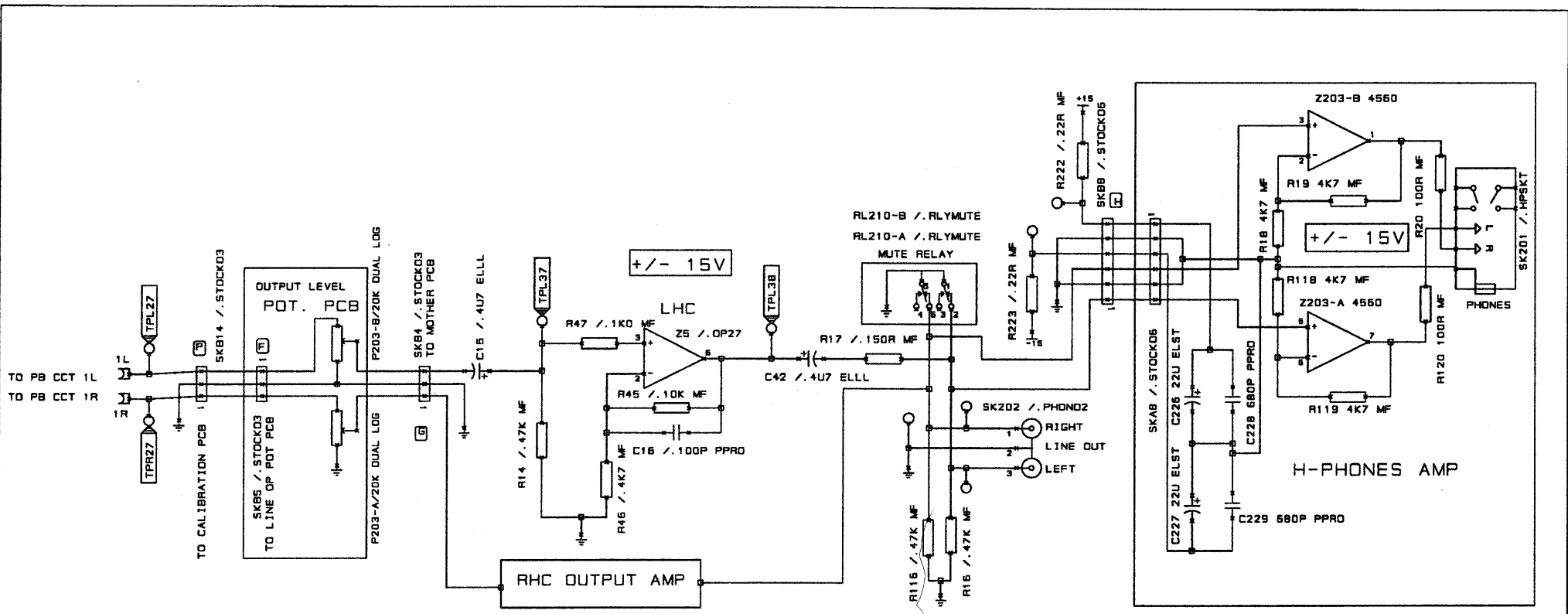

FILE NAME	CO2-0043.501	E1	18-2-92	92014
DRAWN BY	JMG/PN	ISS	DATE	ECN NO.
DATE DRAWN	9-11-91	TITLE LINE OUTPUT AND H/PHONE AMP		
SHT. 5	OF. 5	DRG NO. CO2/0043		
SERVICE MANUAL DRW. NO. H04/ 0015 SHEET 10 OF 10				
ARCAM. A & R CAMBRIDGE LTD, CB5 9PB				